

Hybrid Pro Modular Kit 16

HP-K-16

Hybrid Pro™ Modular exhibits and counters are a perfect solution for the serious exhibitor. Exhibits feature heavy-duty aluminum extrusion frames and push-fit fabric graphics. Count on making an unforgettable impact with Hybrid Pro Modular exhibit kits, counters, and accessories.



features and benefits:

- Silver aluminum extrusion frame
- Slot walls
- Single-sided fabric graphics
- UV graphics
- Easy step-by-step instructions
- Kit includes frame, two slot walls, two fabric graphic panels, sixteen Sintra infills, three backwall counters, two medium monitor mounts*, two spotlights and two molded cases
- Lifetime hardware warranty against manufacturer defects

dimensions:

Hardware

Assembled unit:
232.38" w x 94.5" h x 37.5" d
5903mm(w) x 2400mm(h) x 953mm(d)

Approximate weight:
164 lbs / 75 kg

Shipping

Packing case(s):
1 SCRATE
1 OCH2

Shipping dimensions:
SCRATE:
59" l x 57" h x 33" d
1499mm(l) x 1448mm(h) x 838mm(d)

OCH2:
52" l x 29" h x 15" d
1321mm(l) x 737mm(h) x 381mm(d)

Approximate total shipping weight:
174 lbs / 79 kg

Graphic

Refer to related graphic template for more information.

Visit:
<https://www.theexhibitorshandbook.com/download-graphic-templates>

additional information:

Graphic material:
Dye-sublimation SEG push-fit fabric
UV prints on 6mm Sintra

Counter dimensions:
25.5" w x 39.2" h x 15.1" d
648mm(w) x 996mm(h) x 384mm(d)

Counters (each) hold max weight
50 lbs / 23 kg

Monitor mount holds max weight:
50 lbs / 37 kg

Monitor mount holds monitor sizes:
32" - 55"

*monitors not included



This product may include the following materials for recycle: aluminum, select wood, fabric, cardboard, paper, steel, and plastics.

Tabletop Colors:

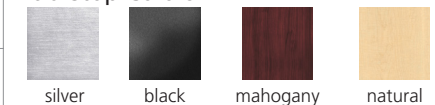

4 person assembly recommended:



We are continually improving and modifying our product range and reserve the right to vary the specifications without prior notice. All dimensions and weights quoted are approximate and we accept no responsibility for variance. E&OE. See Graphic Templates for graphic bleed specifications.

R-HP-K-16

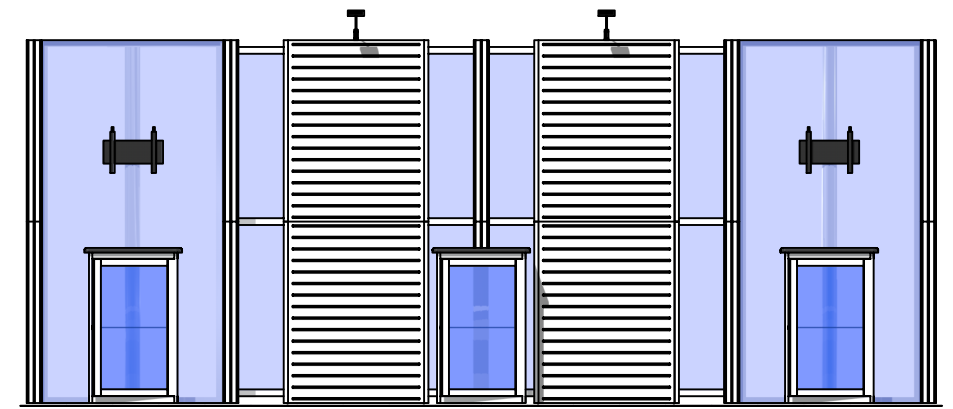
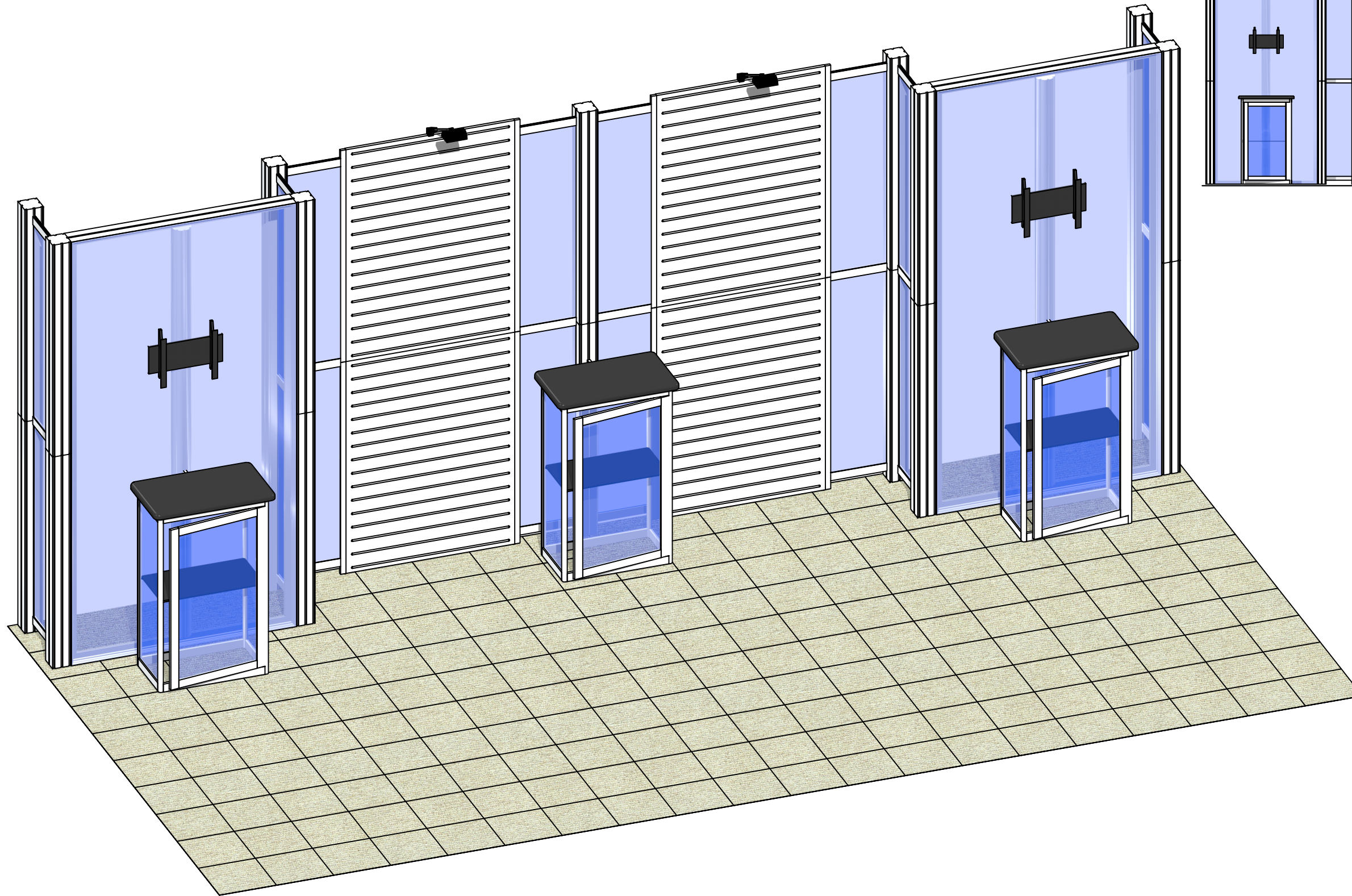

Code	#	Description
R11	8	1200MM (47.24") PHFC4 EXTRUSION WITH MITRE CUT 1 END FOR CB9 ONE END-IB2 HOLES ONE END WITH B
IB2	4	PH INLINE CONNECTOR
CB9	8	CB9 CORNER BRACKET
R9	4	1200MM (47.24") PHFC4 EXTRUSION WITH MITRE CUT BOTH ENDS
EXT-M-MB	2	MEDIUM MONITOR BRACKET FOR MONITORS 32"-55"
GRAPHIC A	1	94.48" H x 47.24" W SINGLE SIDED (UNLINED) DYESUB GRAPHIC W/ FCE2 ALL 4 SIDES
R15	18	1200MM (47.24") 100MM PM4S2 SQUARE EXTRUSION WITH PH2 STOP AT 305MM BOTH ENDS
LED L10S	2	LED SPOTLIGHT, SILVER,3M,UL PLUG W/TRANSFORMER
R8	24	300MM (11.81") PH EXTRUSION WITH LOCKS 2 ENDS
R12	4	1155MM (45.47") 100MM PM4R8 ROUND EXTRUSION WITH PH2 STOP AT 305MM
R111	8	1200MM (47.24") P180 EXTRUSION W/LPJ
R14	2	300MM (11.81") PM4D CONNECTOR WITH TENSION GLIDES
GRAPHIC I1	1	43.26" H x 12.28" W SINGLE SIDED DSG GRAPHIC ON 6MM WHITE SINTRA
GRAPHIC F	1	94.48" H x 47.24" W SINGLE SIDED (UNLINED) DYESUB GRAPHIC W/ FCE2 ALL 4 SIDES
R47	4	900MM x 1200MM LAMINATE SLOTWALL PANEL
GRAPHIC G2	1	43.26" H x 12.28" W SINGLE SIDED DSG GRAPHIC ON 6MM WHITE SINTRA
GRAPHIC G1	1	43.26" H x 12.28" W SINGLE SIDED DSG GRAPHIC ON 6MM WHITE SINTRA
GRAPHIC B2	1	43.26" H x 12.28" W SINGLE SIDED DSG GRAPHIC ON 6MM WHITE SINTRA
GRAPHIC B1	1	43.26" H x 12.28" W SINGLE SIDED DSG GRAPHIC ON 6MM WHITE SINTRA
GRAPHIC H2	1	43.26" H x 12.28" W SINGLE SIDED DSG GRAPHIC ON 6MM WHITE SINTRA
GRAPHIC H1	1	43.26" H x 12.28" W SINGLE SIDED DSG GRAPHIC ON 6MM WHITE SINTRA
GRAPHIC J2	1	43.26" H x 12.28" W SINGLE SIDED DSG GRAPHIC ON 6MM WHITE SINTRA
GRAPHIC J1	1	43.26" H x 12.28" W SINGLE SIDED DSG GRAPHIC ON 6MM WHITE SINTRA
GRAPHIC E2	1	43.26" H x 12.28" W SINGLE SIDED DSG GRAPHIC ON 6MM WHITE SINTRA
GRAPHIC E1	1	43.26" H x 12.28" W SINGLE SIDED DSG GRAPHIC ON 6MM WHITE SINTRA
GRAPHIC D2	1	43.26" H x 12.28" W SINGLE SIDED DSG GRAPHIC ON 6MM WHITE SINTRA
GRAPHIC D1	1	43.26" H x 12.28" W SINGLE SIDED DSG GRAPHIC ON 6MM WHITE SINTRA
GRAPHIC C2	1	43.26" H x 12.28" W SINGLE SIDED DSG GRAPHIC ON 6MM WHITE SINTRA
GRAPHIC C1	1	43.26" H x 12.28" W SINGLE SIDED DSG GRAPHIC ON 6MM WHITE SINTRA
R13	9	600MM (23.62") PM4D CONNECTOR WITH TENSION GLIDES
R48	3	100MM (3.94") PH1 EXTRUSION WITH LOCKS 2 ENDS
GRAPHIC I2	1	43.26" H x 12.28" W SINGLE SIDED DSG GRAPHIC ON 6MM WHITE SINTRA
L180N-900	8	900MM (35.43") 180N DEGREE SILVER LINK EXTRUSION
L180N-600	4	600MM (23.62") 180N DEGREE SILVER LINK EXTRUSION

BOM

R-HP-K-16

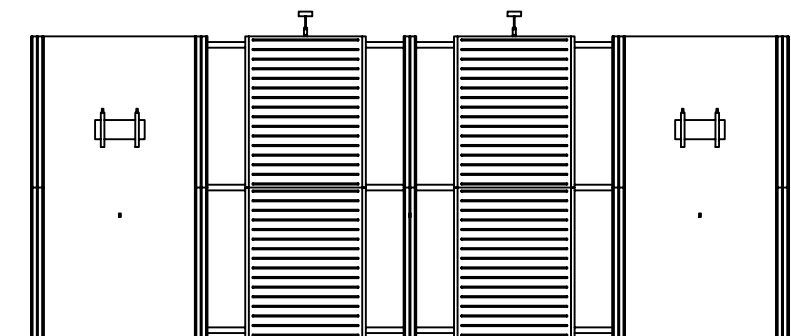
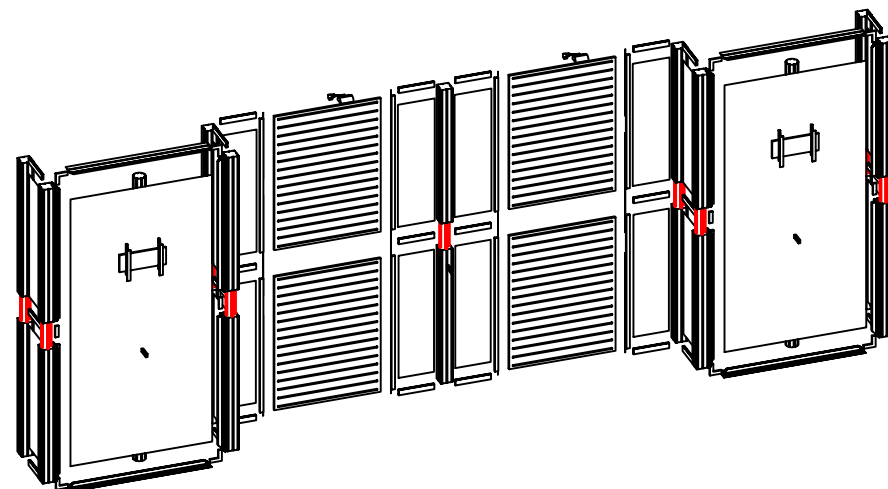
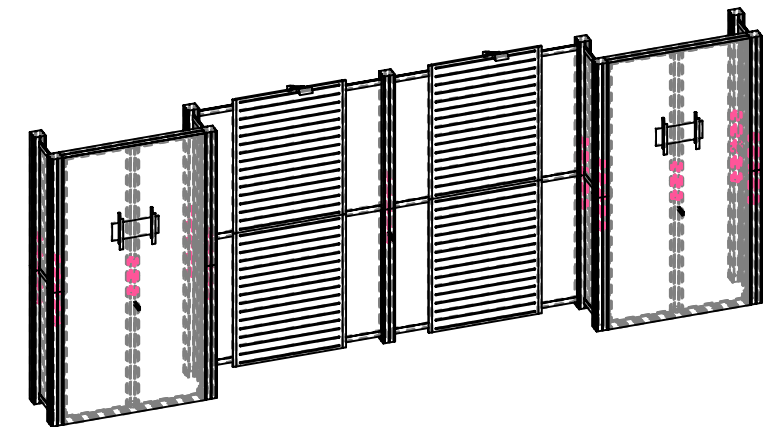
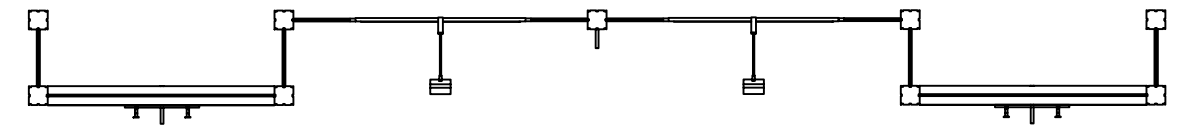

1. Redesign of this exhibit without approval by manufacturer may result in dangerous and unsafe structures. Manufacturer disclaims any responsibility for redesigned exhibits it does not approve in writing.

2. Parts and components such as panels and extrusions are manufactured to metric sizing. Where ever possible sizes have been noted in feet and inches as well as in metric. Below is the imperial to metric sizing table as reference. "Nominal" refers to approximate size.

- | | |
|--------------------|---------------------------------|
| 2400mm = (94 1/2") | Phone Line / Fax |
| 2100mm = (82 5/8") | Internet connection |
| 1800mm = (70 7/8") | Outlet |
| 1500mm = (59") | Main Drop (point of distrution) |
| 1200mm = (47 1/4") | |
| 900mm = (35 1/2") | |
| 600mm = (23 5/8") | |
| 300mm = (11 7/8") | |

--- Wire running under carpet

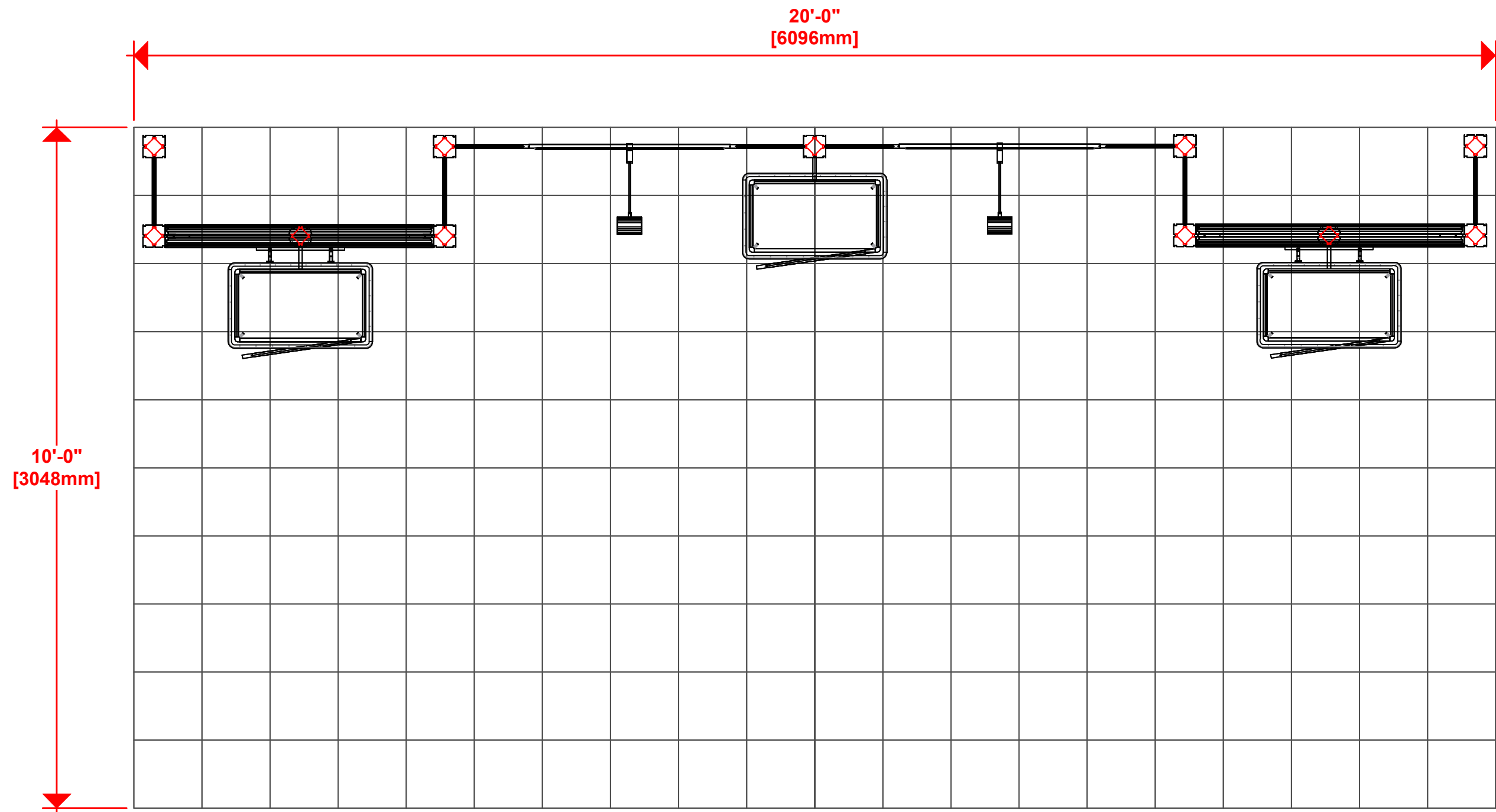

(2) LED L10S LIGHTS = 50W PER STICK

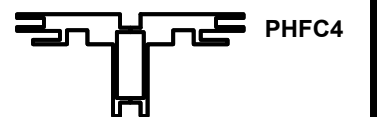
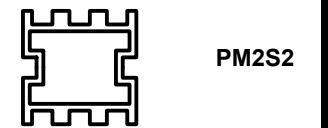

HYBRID PRO RENTAL KIT

Title: SET-UP INSTRUCTIONS

EP

Code	#	Description
R11	8	1200MM (47.24") PHFC4 EXTRUSION WITH MITRE CUT 1 END FOR CB9 ONE END-IB2 HOL
IB2	4	PH INLINE CONNECTOR
CB9	8	CB9 CORNER BRACKET
R9	4	1200MM (47.24") PHFC4 EXTRUSION WITH MITRE CUT BOTH ENDS
R12	2	1155MM (45.47") 100MM PM4R8 ROUND EXTRUSION WITH PH2 STOP AT 305MM
R12	2	1155MM (45.47") 100MM PM4R8 ROUND EXTRUSION WITH LOCKS 1 END
R14	2	300MM (11.81") PM4D CONNECTOR WITH TENSION GLIDES

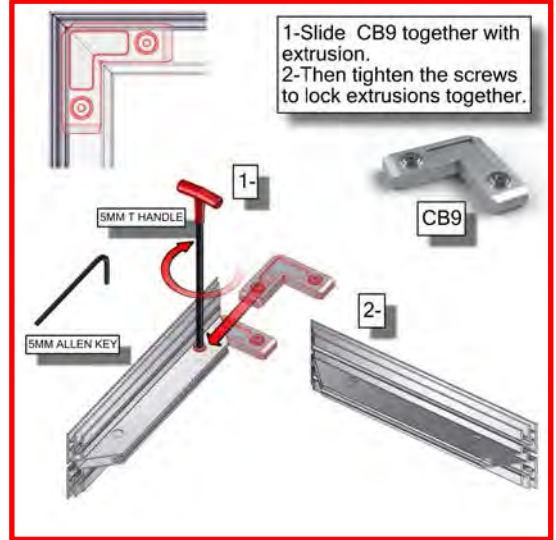
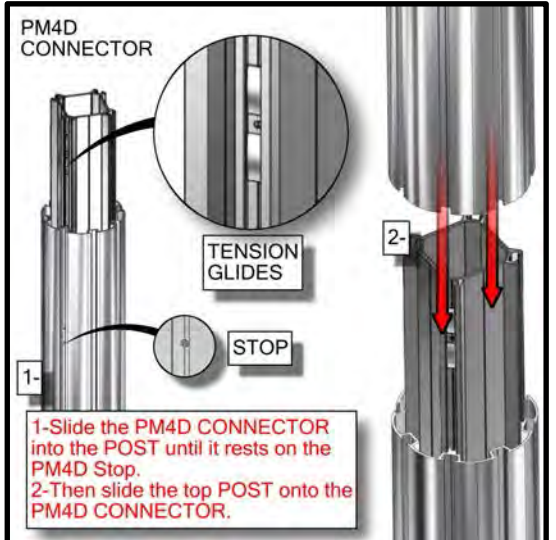
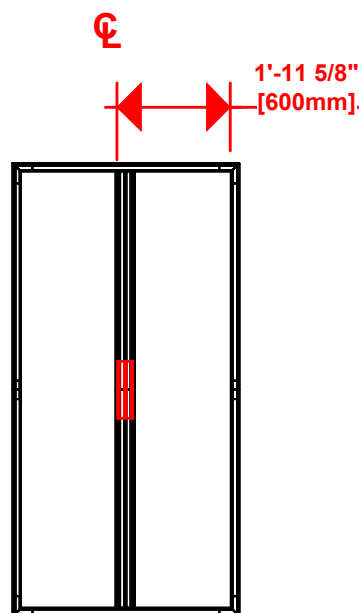
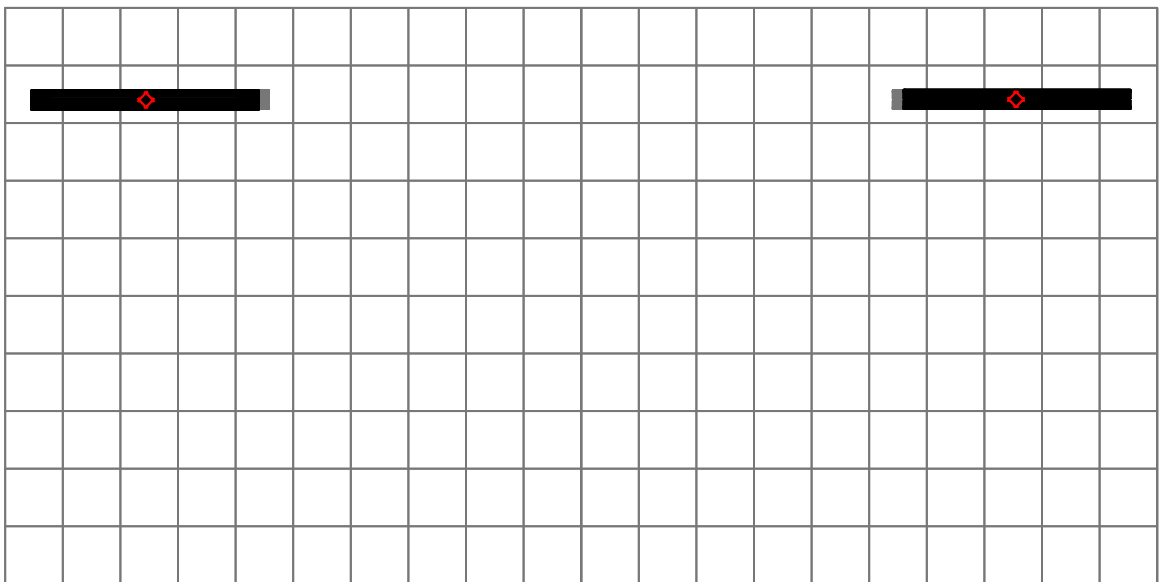
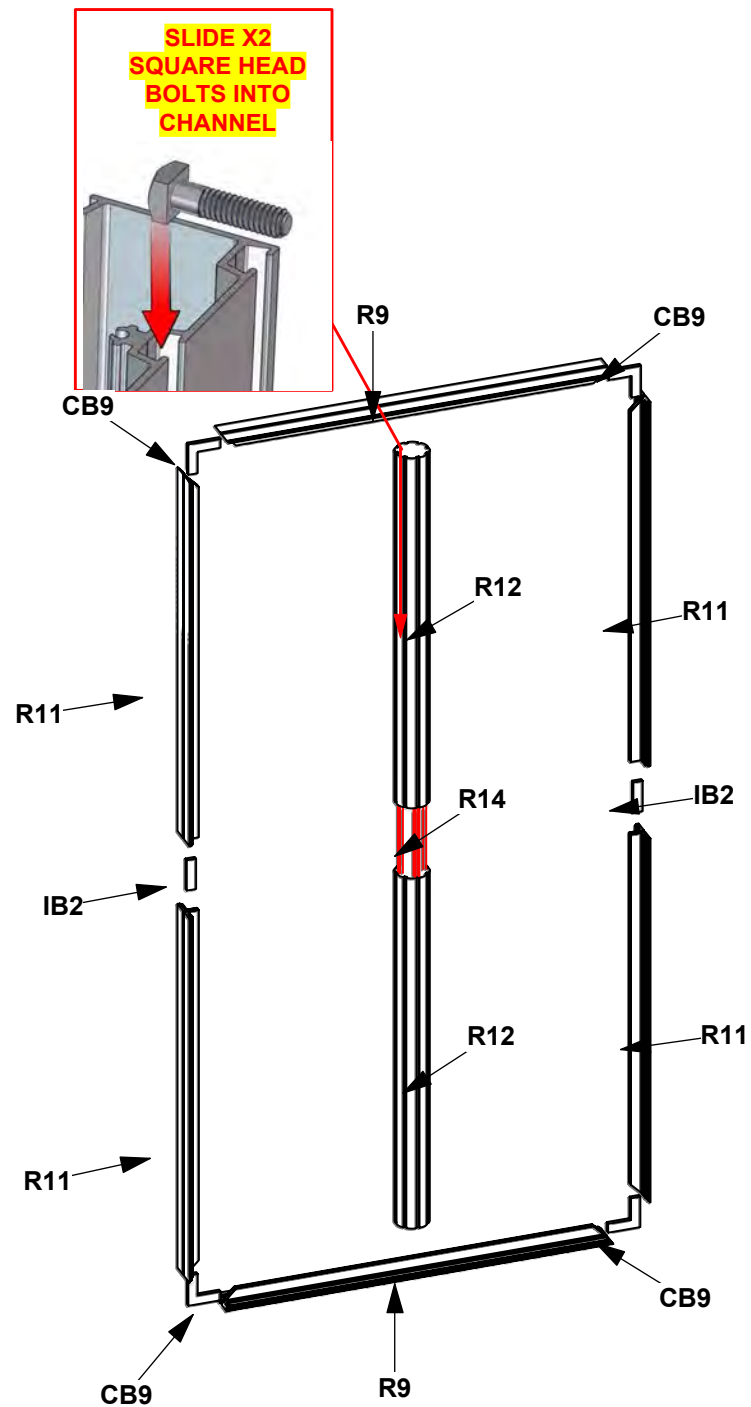

1. Redesign of this exhibit without approval by manufacturer may result in dangerous and unsafe structures. Manufacturer disclaims any responsibility for redesigned exhibits it does not approve in writing.

2. Parts and components such as panels and extrusions are manufactured to metric sizing. Where ever possible sizes have been noted in feet and inches as well as in metric. Below is the imperial to metric sizing table as reference. "Nominal" refers to approximate size.

2400mm = (94 1/2")	Phone Line / Fax
2100mm = (82 5/8")	Internet connection
1800mm = (70 7/8")	Outlet
1500mm = (59")	Main Drop (point of distrution)
1200mm = (47 1/4")	
900mm = (35 1/2")	
600mm = (23 5/8")	
300mm = (11 7/8")	

--- Wire running under carpet

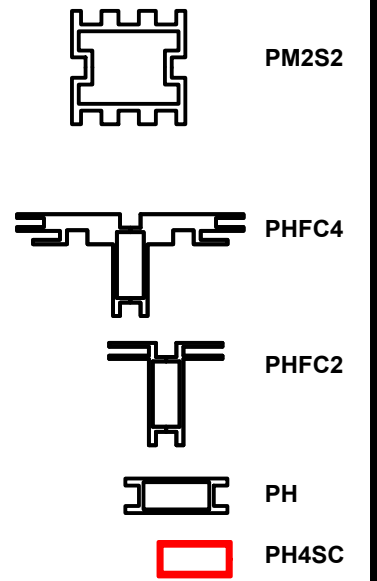

HYBRID PRO RENTAL KIT

Title: SET-UP INSTRUCTIONS

BUILD 2 UNITS

Code	#	Description
R8	8	300MM (11.81") PH EXTRUSION WITH LOCKS 2 ENDS
R47	2	900MM x 1200MM LAMINATE SLOTWALL PANEL
GRAPHIC B2	1	43.26" H x 12.28" W SINGLE SIDED DSG GRAPHIC ON 6MM WHITE SINTRA
GRAPHIC B1	1	43.26" H x 12.28" W SINGLE SIDED DSG GRAPHIC ON 6MM WHITE SINTRA
GRAPHIC E2	1	43.26" H x 12.28" W SINGLE SIDED DSG GRAPHIC ON 6MM WHITE SINTRA
GRAPHIC E1	1	43.26" H x 12.28" W SINGLE SIDED DSG GRAPHIC ON 6MM WHITE SINTRA
GRAPHIC D2	1	43.26" H x 12.28" W SINGLE SIDED DSG GRAPHIC ON 6MM WHITE SINTRA
GRAPHIC D1	1	43.26" H x 12.28" W SINGLE SIDED DSG GRAPHIC ON 6MM WHITE SINTRA
GRAPHIC C2	1	43.26" H x 12.28" W SINGLE SIDED DSG GRAPHIC ON 6MM WHITE SINTRA
GRAPHIC C1	1	43.26" H x 12.28" W SINGLE SIDED DSG GRAPHIC ON 6MM WHITE SINTRA

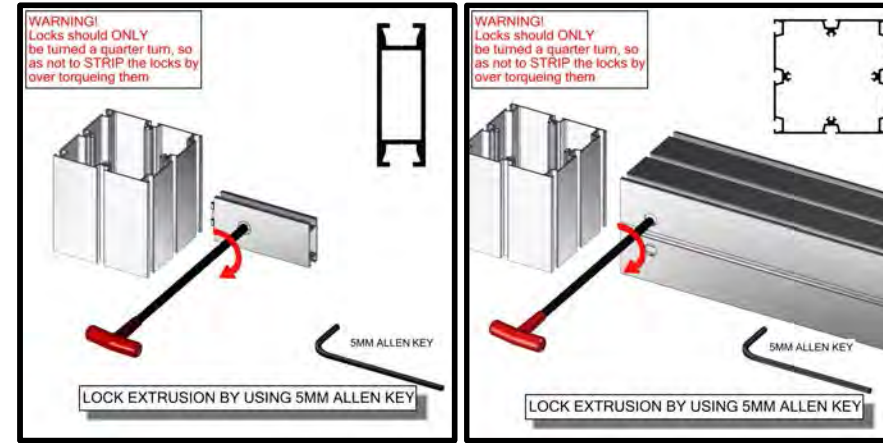

1. Redesign of this exhibit without approval by manufacturer may result in dangerous and unsafe structures. Manufacturer disclaims any responsibility for redesigned exhibits it does not approve in writing.

2. Parts and components such as panels and extrusions are manufactured to metric sizing. Where ever possible sizes have been noted in feet and inches as well as in metric. Below is the imperial to metric sizing table as reference. "Nominal" refers to approximate size.

2400mm = (94 1/2")	Phone Line / Fax
2100mm = (82 5/8")	Internet connection
1800mm = (70 7/8")	Outlet
1500mm = (59")	Main Drop (point of distrution)
1200mm = (47 1/4")	
900mm = (35 1/2")	
600mm = (23 5/8")	
300mm = (11 7/8")	

--- Wire running under carpet

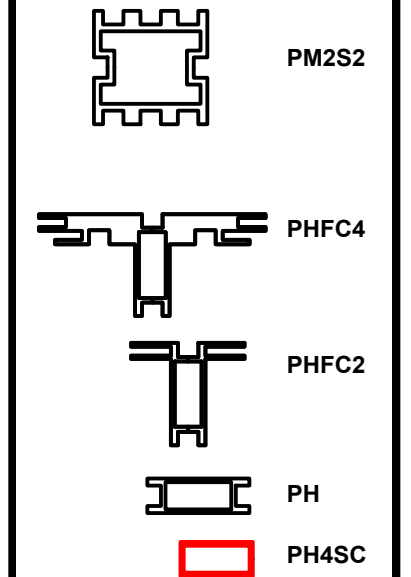
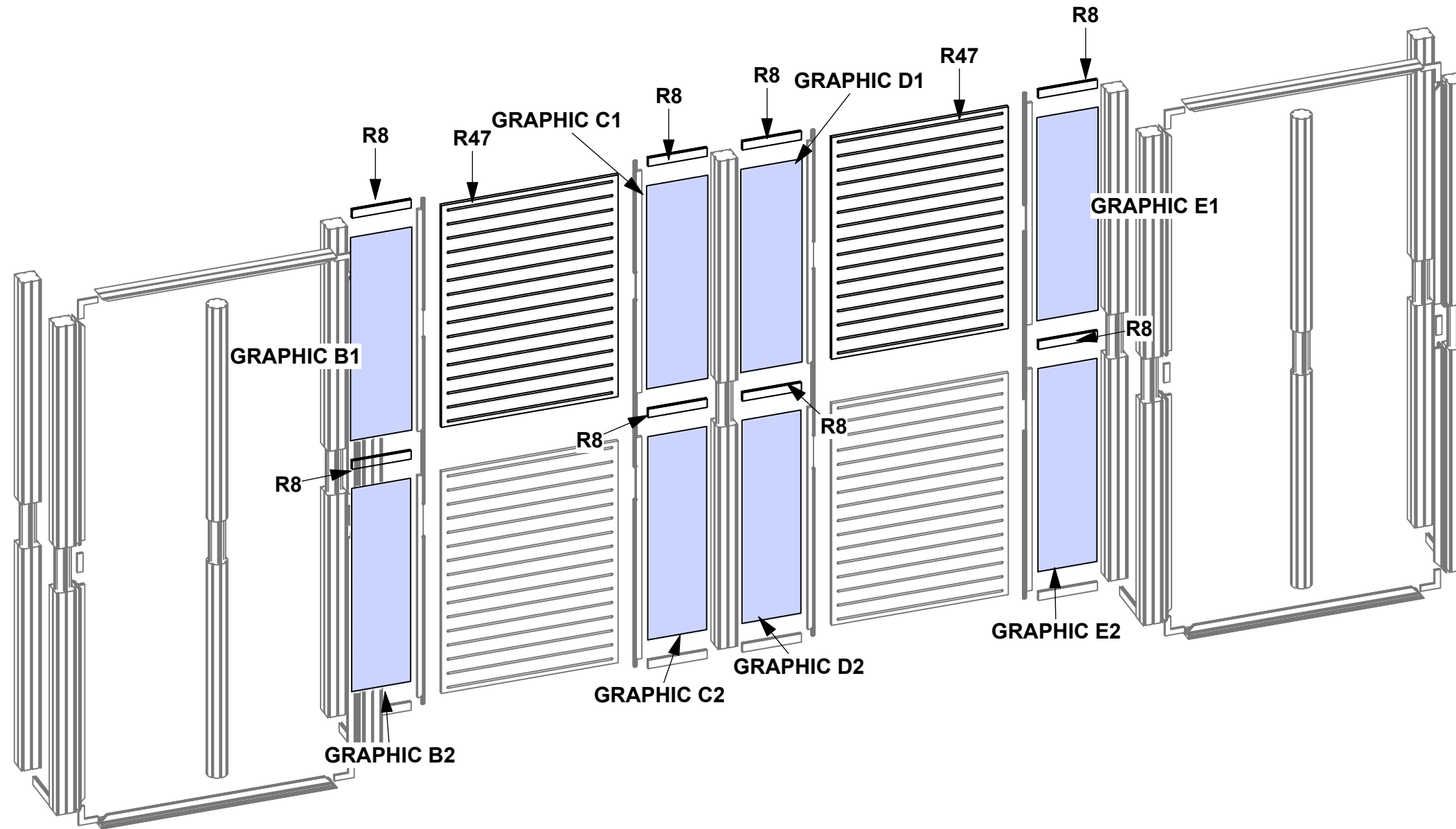

HYBRID PRO RENTAL KIT

Title: SET-UP INSTRUCTIONS

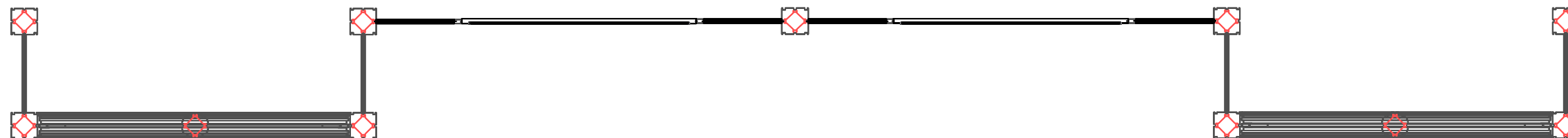

Code	#	Description
R8	8	300MM (11.81") PH EXTRUSION WITH LOCKS 2 ENDS
GRAPHIC I1	1	43.26" H x 12.28" W SINGLE SIDED DSG GRAPHIC ON 6MM WHITE SINTRA
GRAPHIC G2	1	43.26" H x 12.28" W SINGLE SIDED DSG GRAPHIC ON 6MM WHITE SINTRA
GRAPHIC G1	1	43.26" H x 12.28" W SINGLE SIDED DSG GRAPHIC ON 6MM WHITE SINTRA
GRAPHIC H2	1	43.26" H x 12.28" W SINGLE SIDED DSG GRAPHIC ON 6MM WHITE SINTRA
GRAPHIC H1	1	43.26" H x 12.28" W SINGLE SIDED DSG GRAPHIC ON 6MM WHITE SINTRA
GRAPHIC J2	1	43.26" H x 12.28" W SINGLE SIDED DSG GRAPHIC ON 6MM WHITE SINTRA
GRAPHIC J1	1	43.26" H x 12.28" W SINGLE SIDED DSG GRAPHIC ON 6MM WHITE SINTRA
GRAPHIC I2	1	43.26" H x 12.28" W SINGLE SIDED DSG GRAPHIC ON 6MM WHITE SINTRA

1. Redesign of this exhibit without approval by manufacturer may result in dangerous and unsafe structures. Manufacturer disclaims any responsibility for redesigned exhibits it does not approve in writing.

2. Parts and components such as panels and extrusions are manufactured to metric sizing. Where ever possible sizes have been noted in feet and inches as well as in metric. Below is the imperial to metric sizing table as reference. "Nominal" refers to approximate size.

2400mm = (94 1/2")	Phone Line / Fax
2100mm = (82 5/8")	Internet connection
1800mm = (70 7/8")	Outlet
1500mm = (59")	Main Drop (point of distrution)
1200mm = (47 1/4")	
900mm = (35 1/2")	
600mm = (23 5/8")	
300mm = (11 7/8")	

--- Wire running under carpet

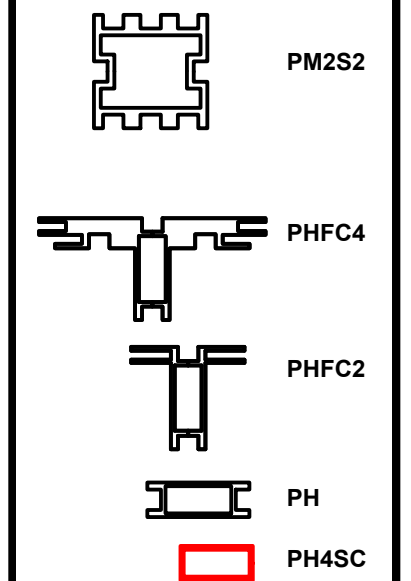
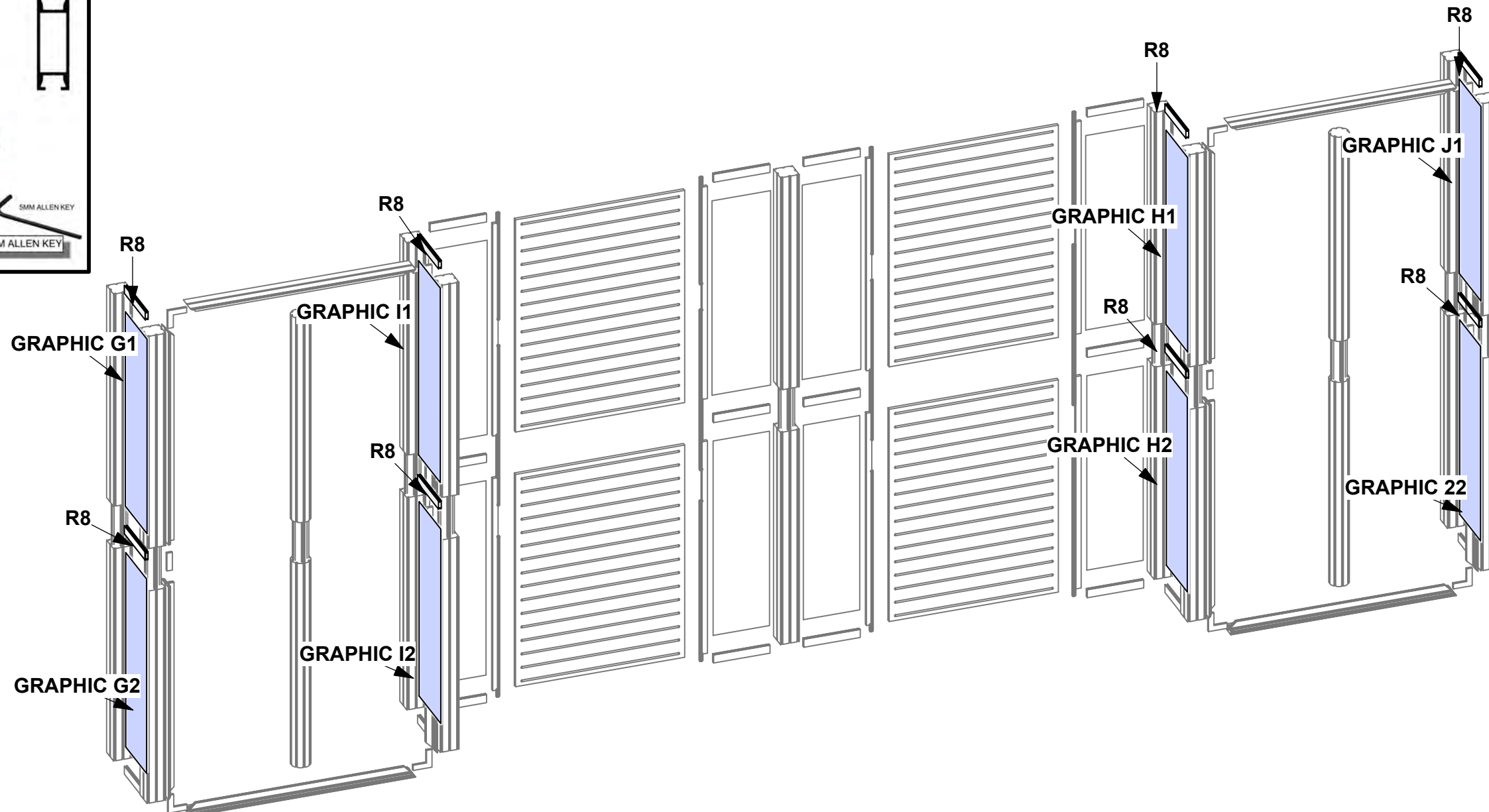

HYBRID PRO RENTAL KIT

Title: SET-UP INSTRUCTIONS

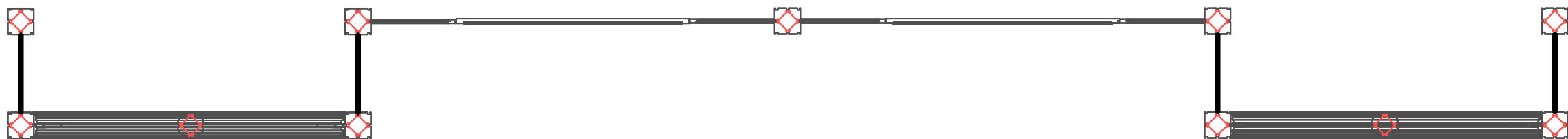

Code	#	Description
EXT-M-MB	2	MEDIUM MONITOR BRACKET FOR MONITORS 32"-55"
GRAPHIC A	1	94.48" H x 47.24" W SINGLE SIDED (UNLINED) DYESUB GRAPHIC W/ FCE2 A
GRAPHIC F	1	94.48" H x 47.24" W SINGLE SIDED (UNLINED) DYESUB GRAPHIC W/ FCE2 A
R48	3	100MM (3.94") PH1 EXTRUSION WITH LOCKS 2 ENDS

1. Redesign of this exhibit without approval by manufacturer may result in dangerous and unsafe structures. Manufacturer disclaims any responsibility for redesigned exhibits it does not approve in writing.

2. Parts and components such as panels and extrusions are manufactured to metric sizing. Where ever possible sizes have been noted in feet and inches as well as in metric. Below is the imperial to metric sizing table as reference. "Nominal" refers to approximate size.

2400mm = (94 1/2")	Phone Line / Fax
2100mm = (82 5/8")	Internet connection
1800mm = (70 7/8")	Outlet
1500mm = (59")	Main Drop (point of distrution)
1200mm = (47 1/4")	
900mm = (35 1/2")	
600mm = (23 5/8")	
300mm = (11 7/8")	

--- Wire running under carpet

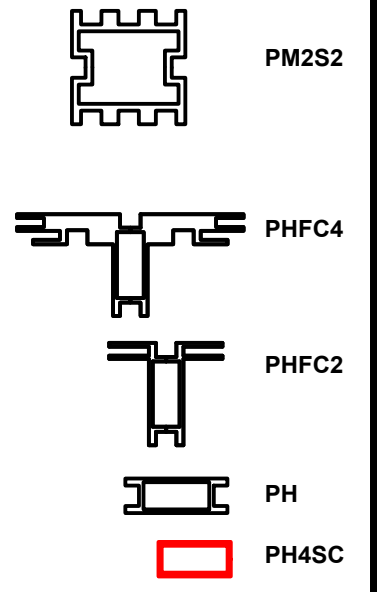
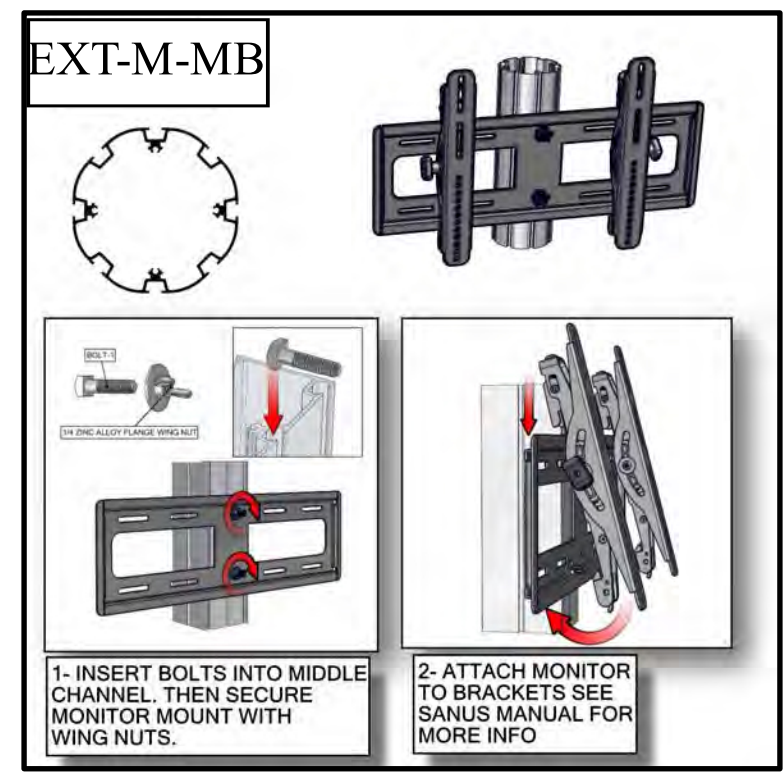
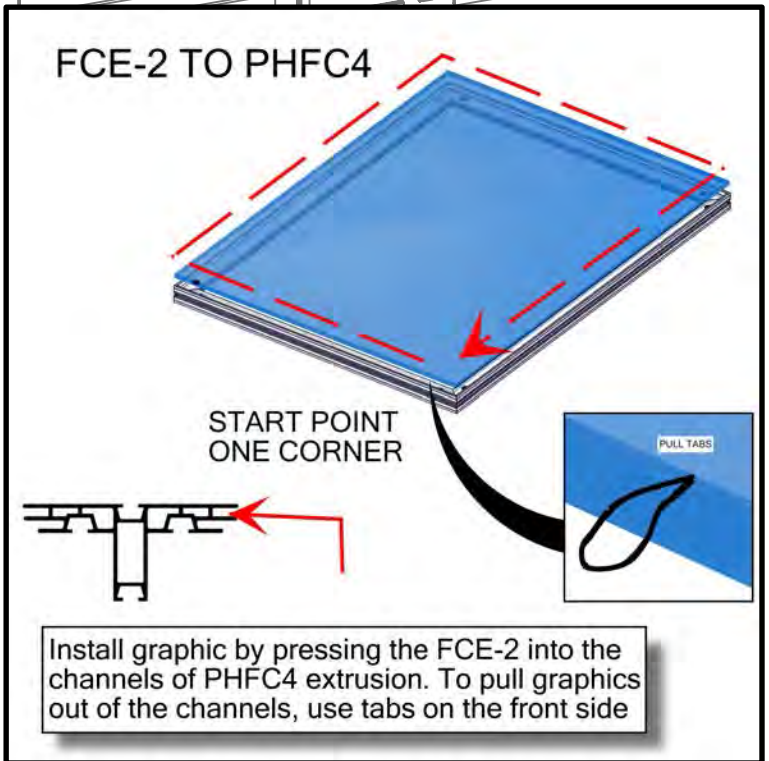
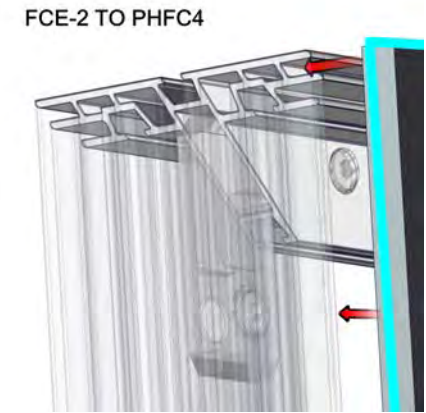
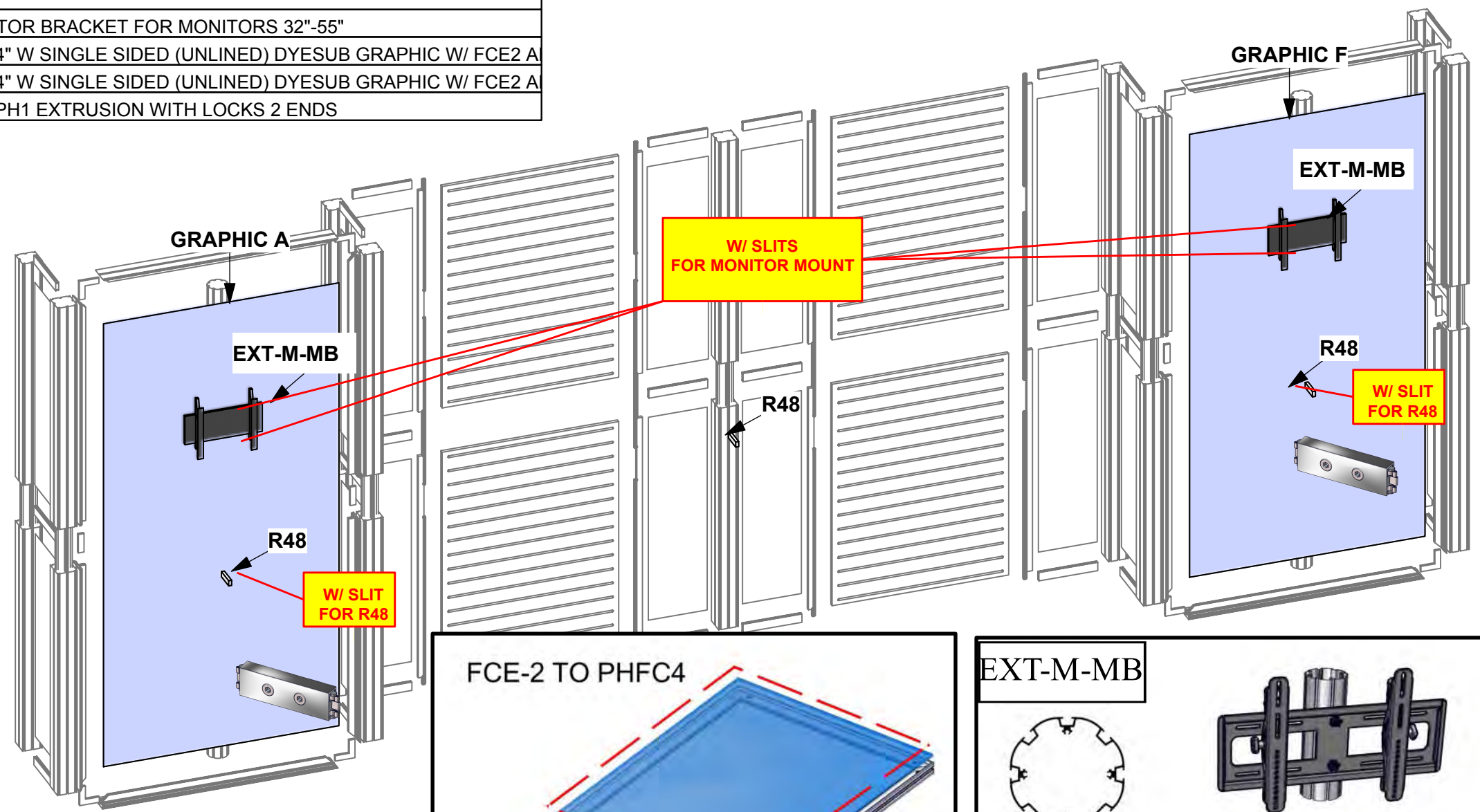
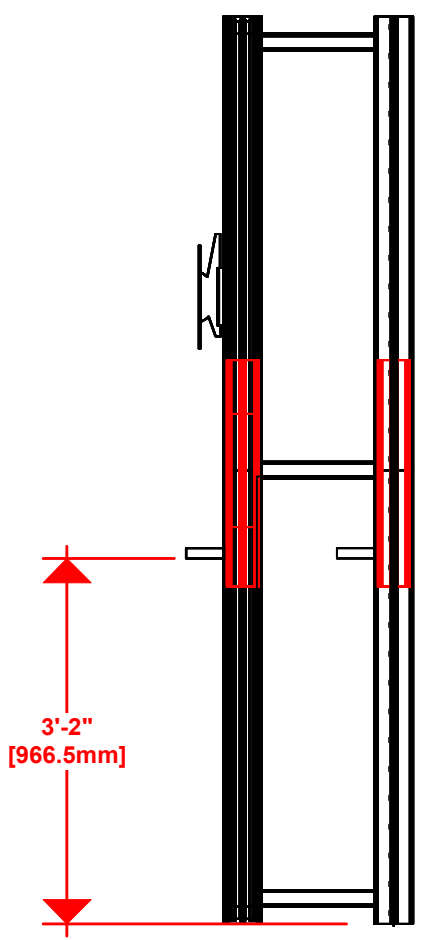

HYBRID PRO RENTAL KIT

Title: SET-UP INSTRUCTIONS

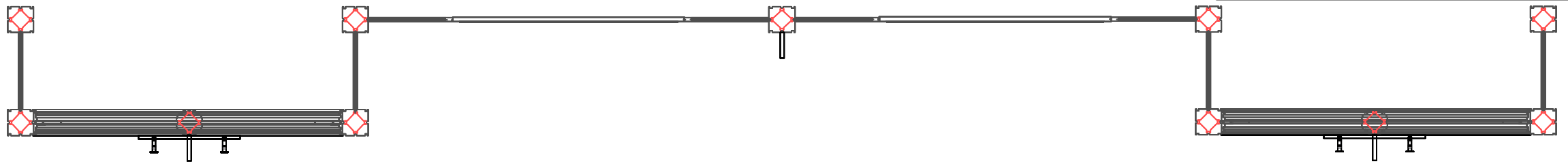

Code	#	Description
LED L10S	2	LED SPOTLIGHT, SILVER,3M,UL PLUG W/TRANSFORMER

1. Redesign of this exhibit without approval by manufacturer may result in dangerous and unsafe structures. Manufacturer disclaims any responsibility for redesigned exhibits it does not approve in writing.

2. Parts and components such as panels and extrusions are manufactured to metric sizing. Where ever possible sizes have been noted in feet and inches as well as in metric. Below is the imperial to metric sizing table as reference. "Nominal" refers to approximate size.

2400mm = (94 1/2")	☒ Phone Line / Fax
2100mm = (82 5/8")	☒ Internet connection
1800mm = (70 7/8")	☒ Outlet
1500mm = (59")	☒ Main Drop (point of distrution)
1200mm = (47 1/4")	
900mm = (35 1/2")	
600mm = (23 5/8")	
300mm = (11 7/8")	

--- Wire running under carpet

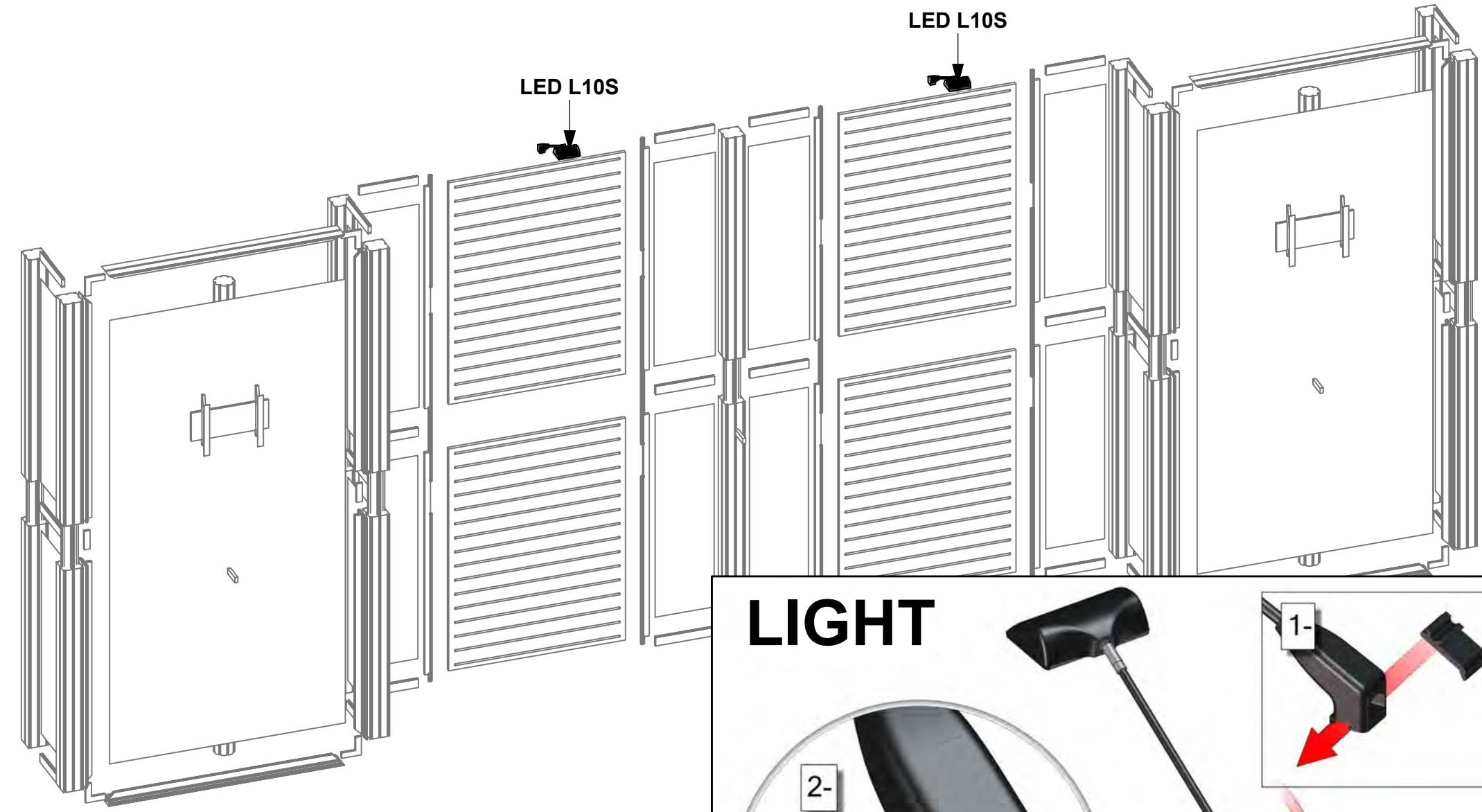

LIGHT

1- Slide light clip onto the LIGHT.

2- Then slide the LIGHT into the channel at an angle and then gently lower down.

PANEL

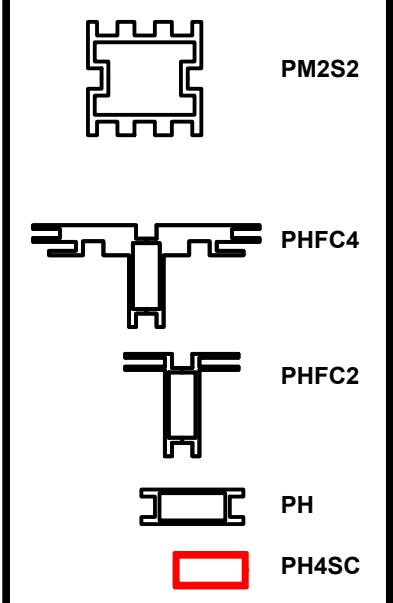

HYBRID PRO RENTAL KIT

Title: SET-UP INSTRUCTIONS

R-LN-CU-06
W/ SLIT

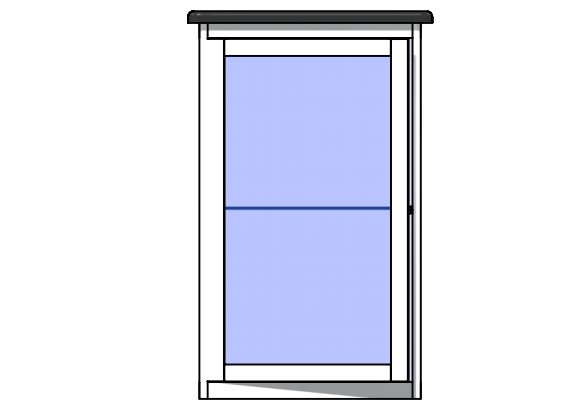
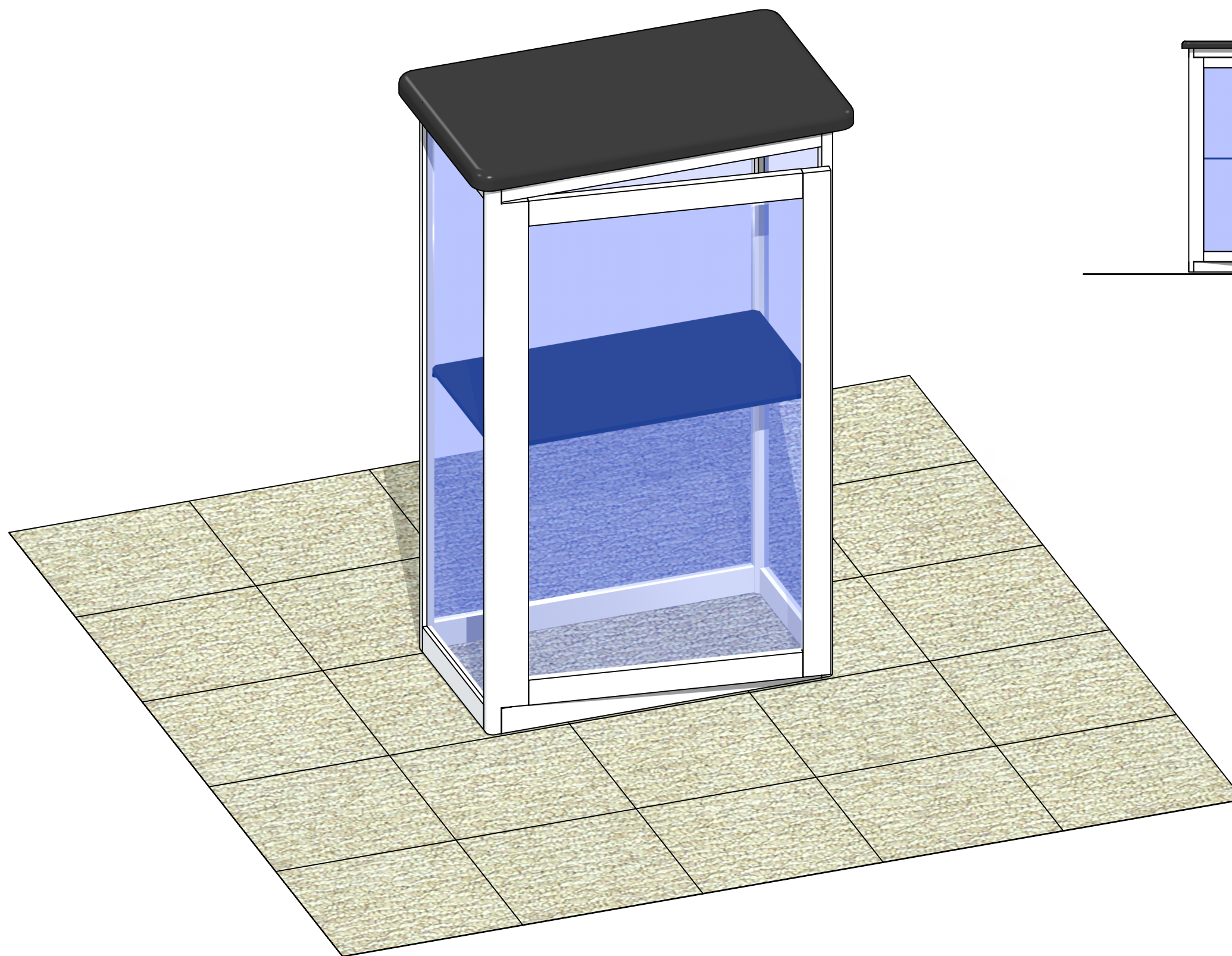

Code	#	Description
V-CU-CAB-01-S	3	292MM X 553 (11 1/2" X 21 3/4") INTERNAL SHELF FOR V-CU-CAB-01
R50	12	280MM (11") PH WITH SLIDE LOCK AT BOTH ENDS
R54	6	922MM X 292MM (36 5/16" X 11 1/2") SIDE SINTRA/FOAMEX
R53	3	581MM X 1000MM (22 7/8" X 39 3/8") FRONT FRAME W/GFX INFILL W/SLITS ON PH□□□□□
R52	3	581MM X 1000MM (22 7/8" X 39 3/8") CABINET DOOR W/GFX INFILL
V-SS1	12	SHELF SUPPORT
V-CW-CT-01	3	384MM X 646MM (15 1/8" X 25 7/16") HYBRID RECTANGLE TOP

BOM

R-LN-CU-06
W/ SLIT
(3) UNITS

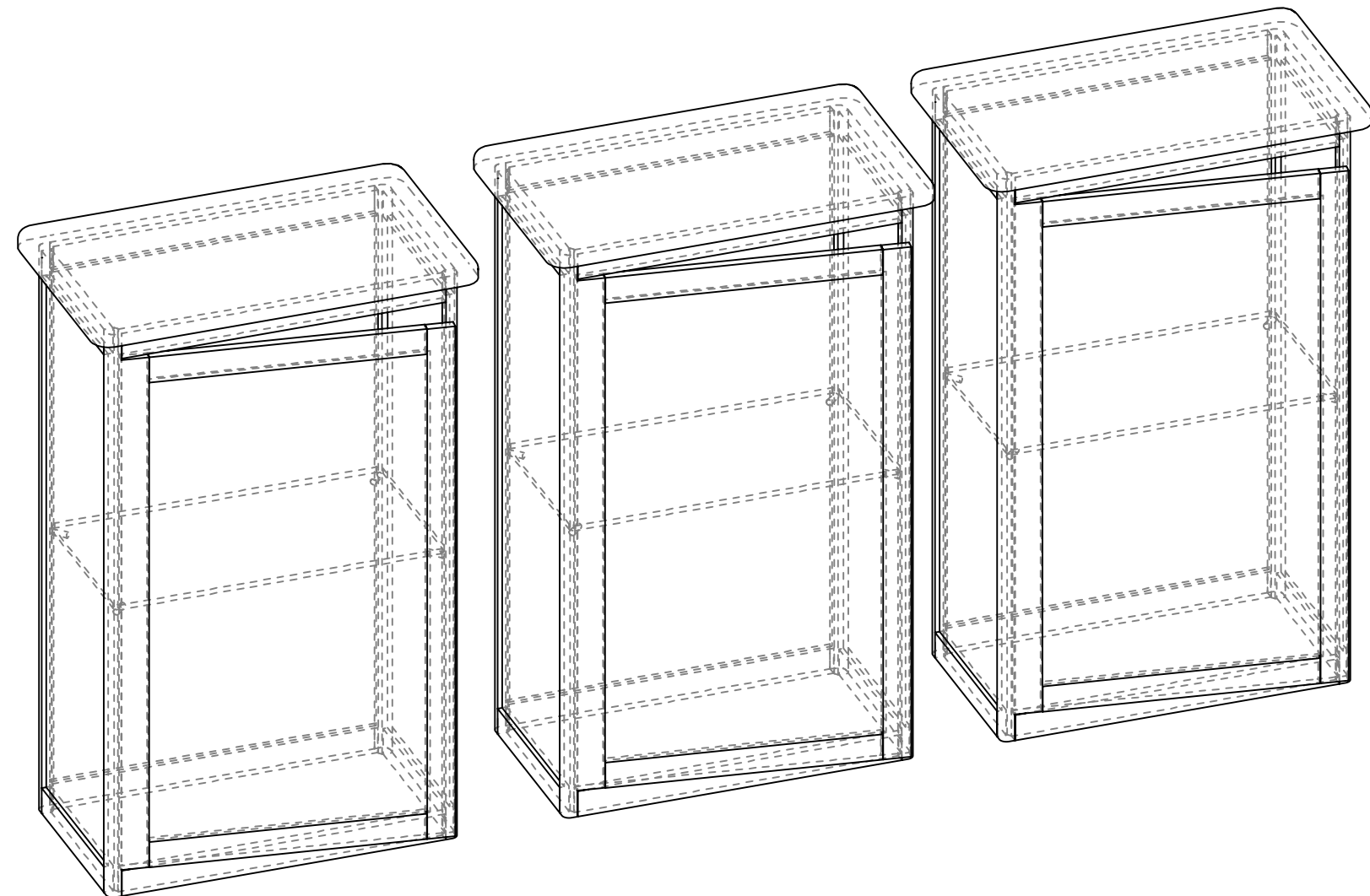
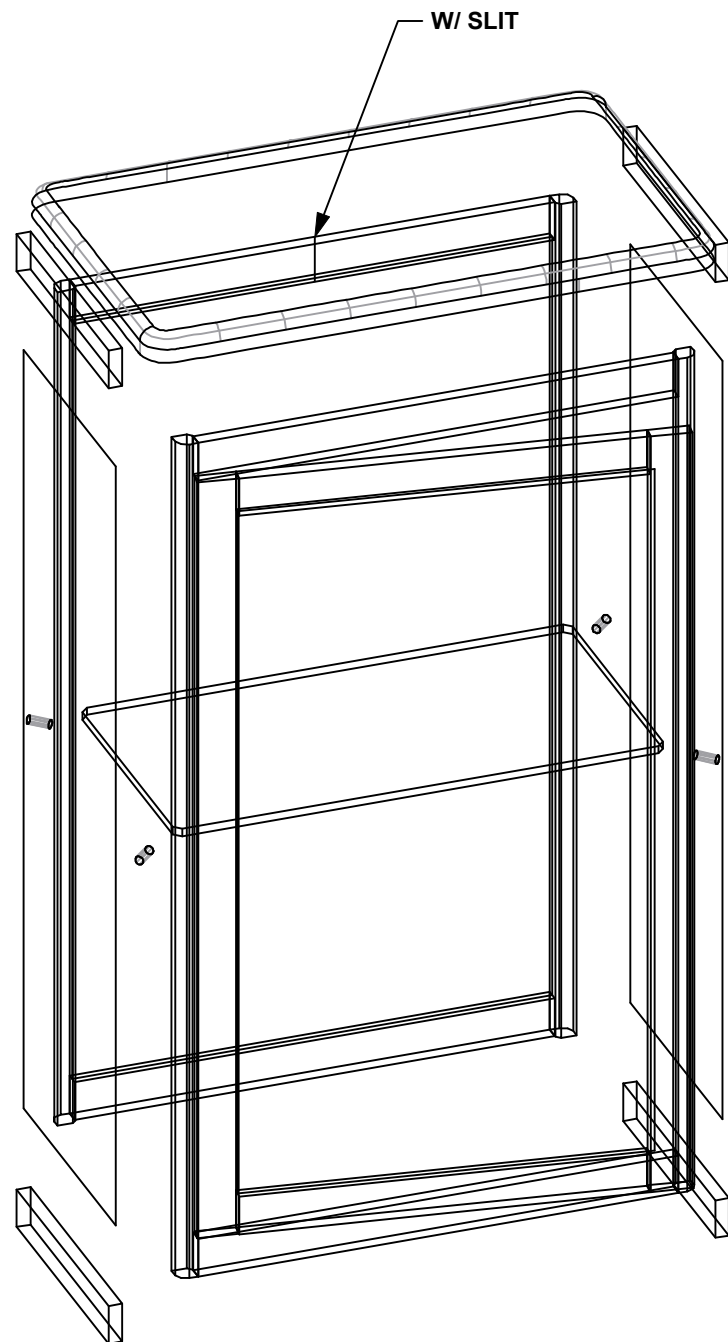
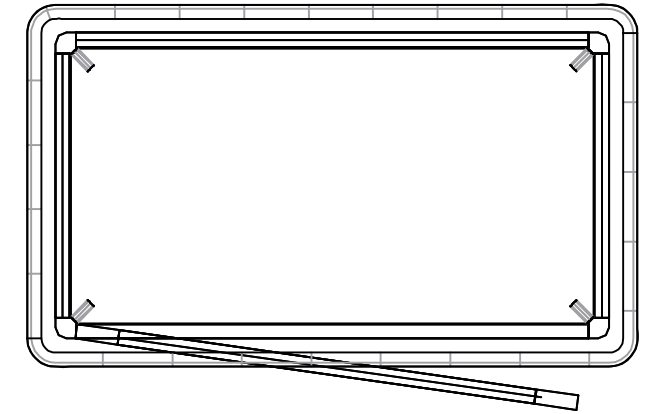

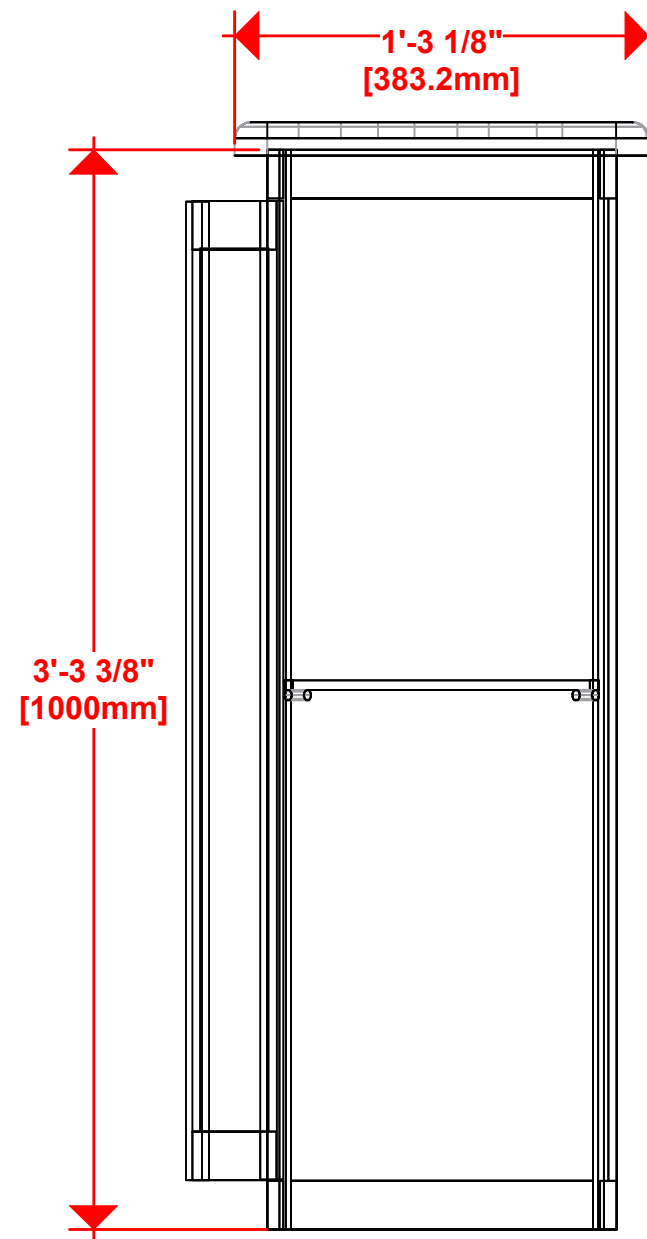
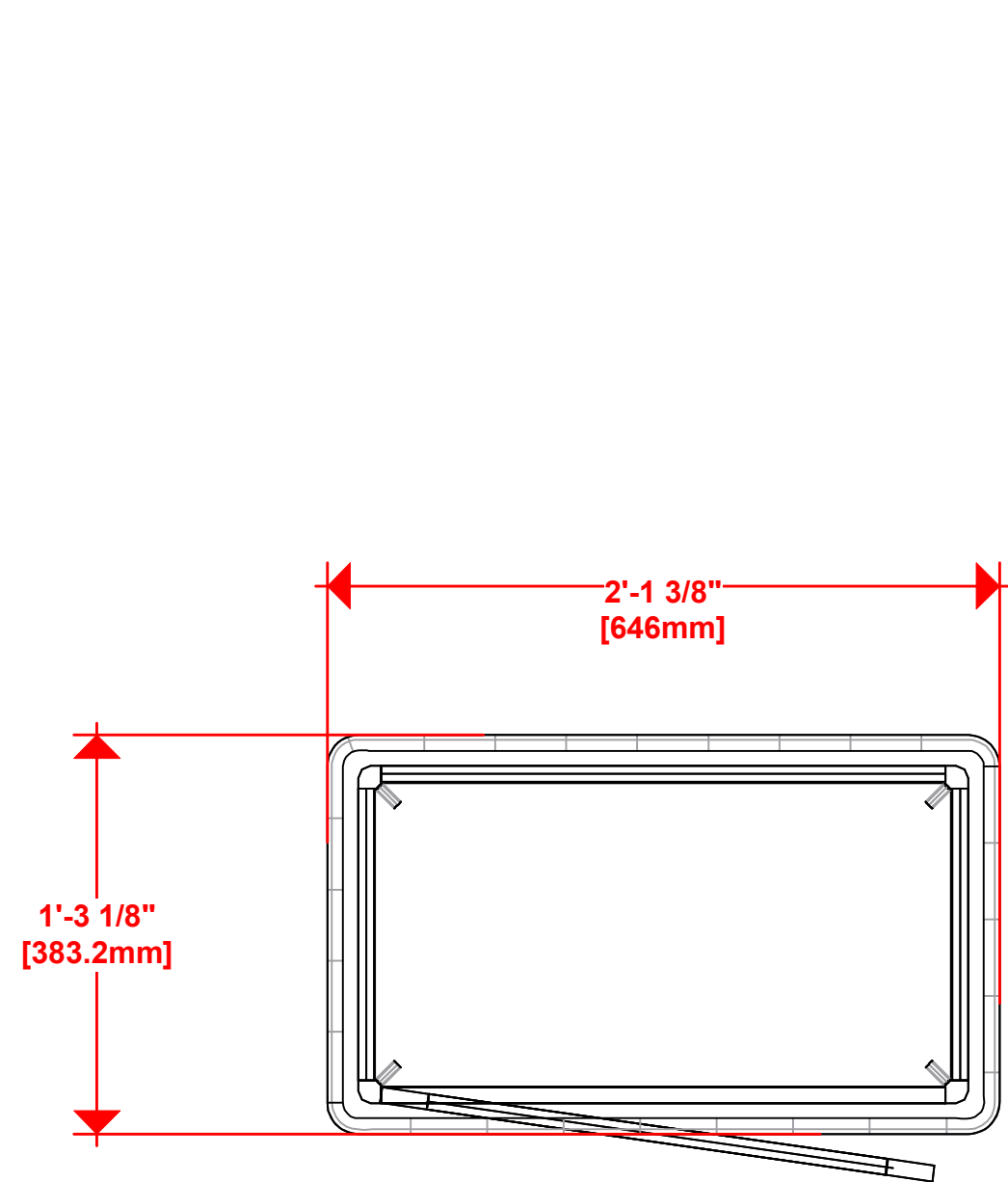

1. Redesign of this exhibit without approval by manufacturer may result in dangerous and unsafe structures. Manufacturer disclaims any responsibility for redesigned exhibits it does not approve in writing.

2. Parts and components such as panels and extrusions are manufactured to metric sizing. Where ever possible sizes have been noted in feet and inches as well as in metric. Below is the imperial to metric sizing table as reference. "Nominal" refers to approximate size.

- | | |
|--------------------|-----------------------------------|
| 2400mm = (94 1/2") | ☒ Phone Line / Fax |
| 2100mm = (82 5/8") | ☒ Internet connection |
| 1800mm = (70 7/8") | ☒ Outlet |
| 1500mm = (59") | ☒ Main Drop (point of distrution) |
| 1200mm = (47 1/4") | |
| 900mm = (35 1/2") | |
| 600mm = (23 5/8") | |
| 300mm = (11 7/8") | |
- Wire running under carpet

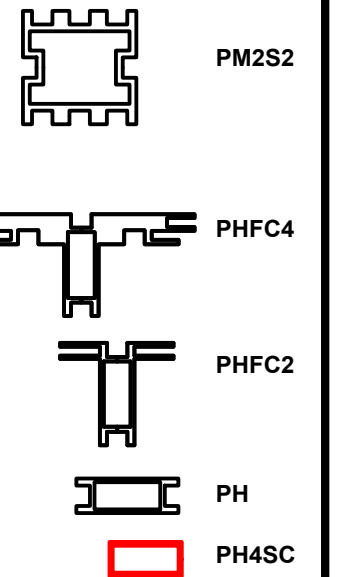

HYBRID PRO RENTAL KIT

Title: SET-UP INSTRUCTIONS

Code	#	Description
R50	2	280MM (11") PH WITH SLIDE LOCK AT BOTH ENDS
R53	1	581MM X 1000MM (22 7/8" X 39 3/8") FRONT FRAME W/GFX INFILL W/SLITS ON PH□□□
R52	1	581MM X 1000MM (22 7/8" X 39 3/8") CABINET DOOR W/GFX INFILL

1. Redesign of this exhibit without approval by manufacturer may result in dangerous and unsafe structures. Manufacturer disclaims any responsibility for redesigned exhibits it does not approve in writing.

2. Parts and components such as panels and extrusions are manufactured to metric sizing. Where ever possible sizes have been noted in feet and inches as well as in metric. Below is the imperial to metric sizing table as reference. "Nominal" refers to approximate size.

2400mm = (94 1/2")	Phone Line / Fax
2100mm = (82 5/8")	Internet connection
1800mm = (70 7/8")	Outlet
1500mm = (59")	Main Drop (point of distrution)
1200mm = (47 1/4")	
900mm = (35 1/2")	
600mm = (23 5/8")	
300mm = (11 7/8")	

--- Wire running under carpet

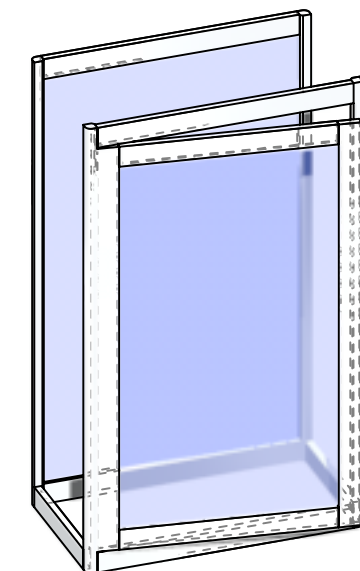
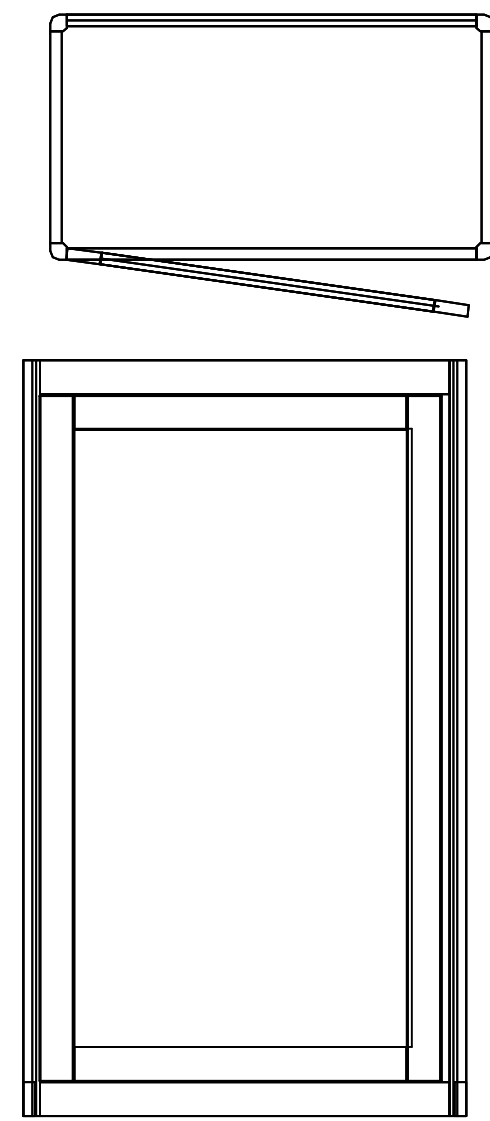
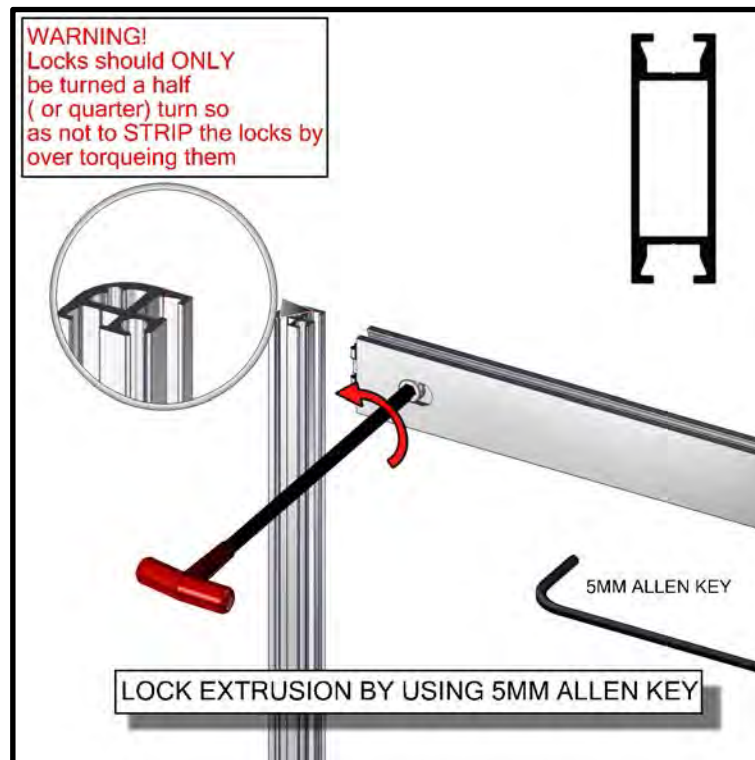
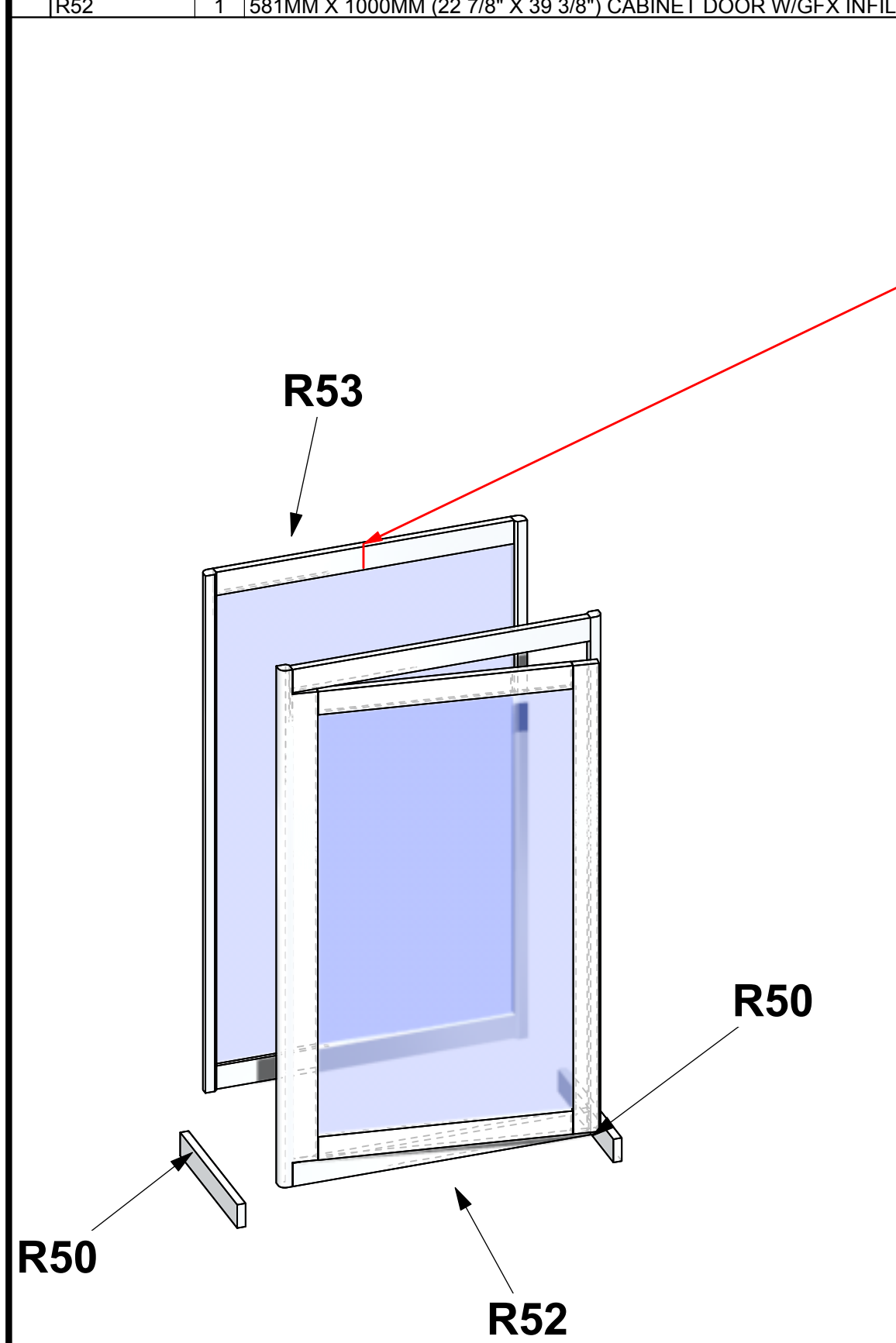
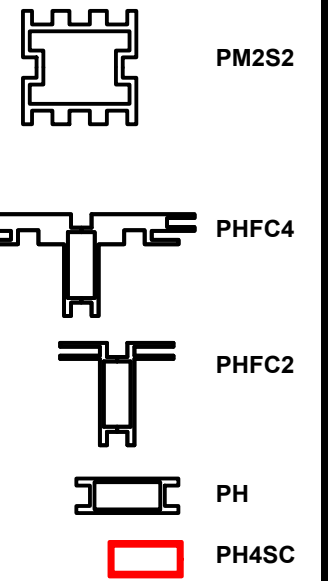

HYBRID PRO RENTAL KIT

Title: SET-UP INSTRUCTIONS

Code	#	Description
V-CU-CAB-01-S	1	292MM X 553 (11 1/2" X 21 3/4") INTERNAL SHELF FOR V-CU-CAB-01
R50	2	280MM (11") PH WITH SLIDE LOCK AT BOTH ENDS
R54	2	922MM X 292MM (36 5/16" X 11 1/2") SIDE SINTRA/FOAMEX
V-SS1	4	SHELF SUPPORT

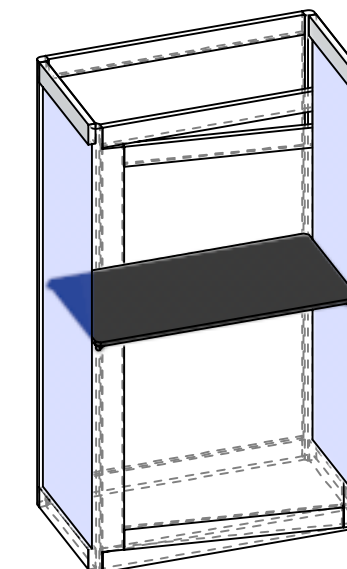
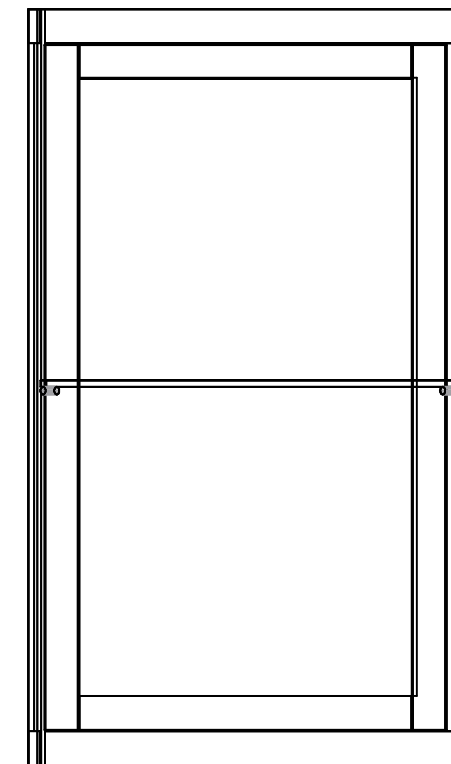
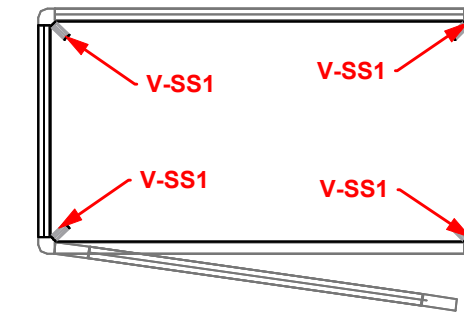
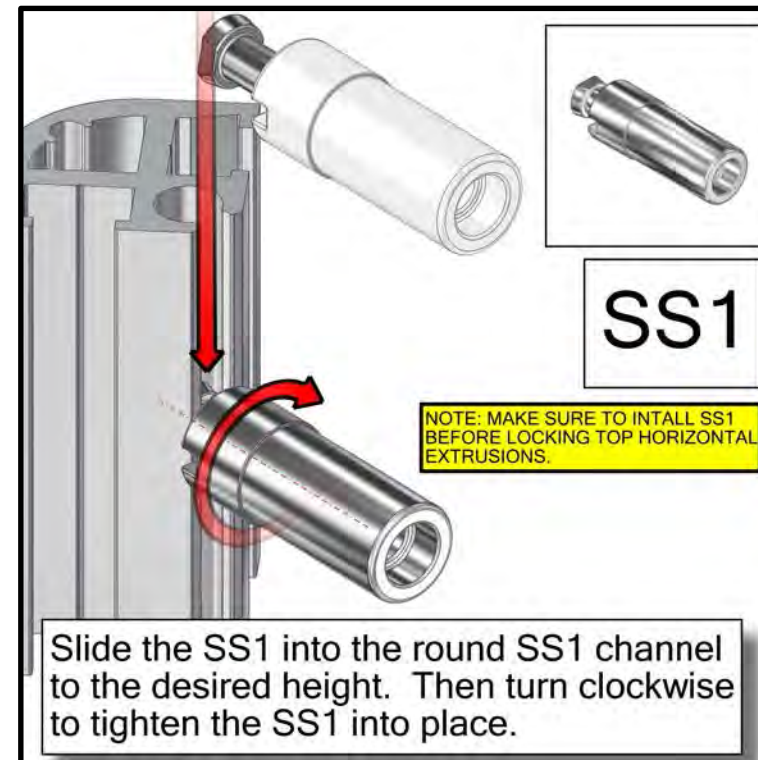
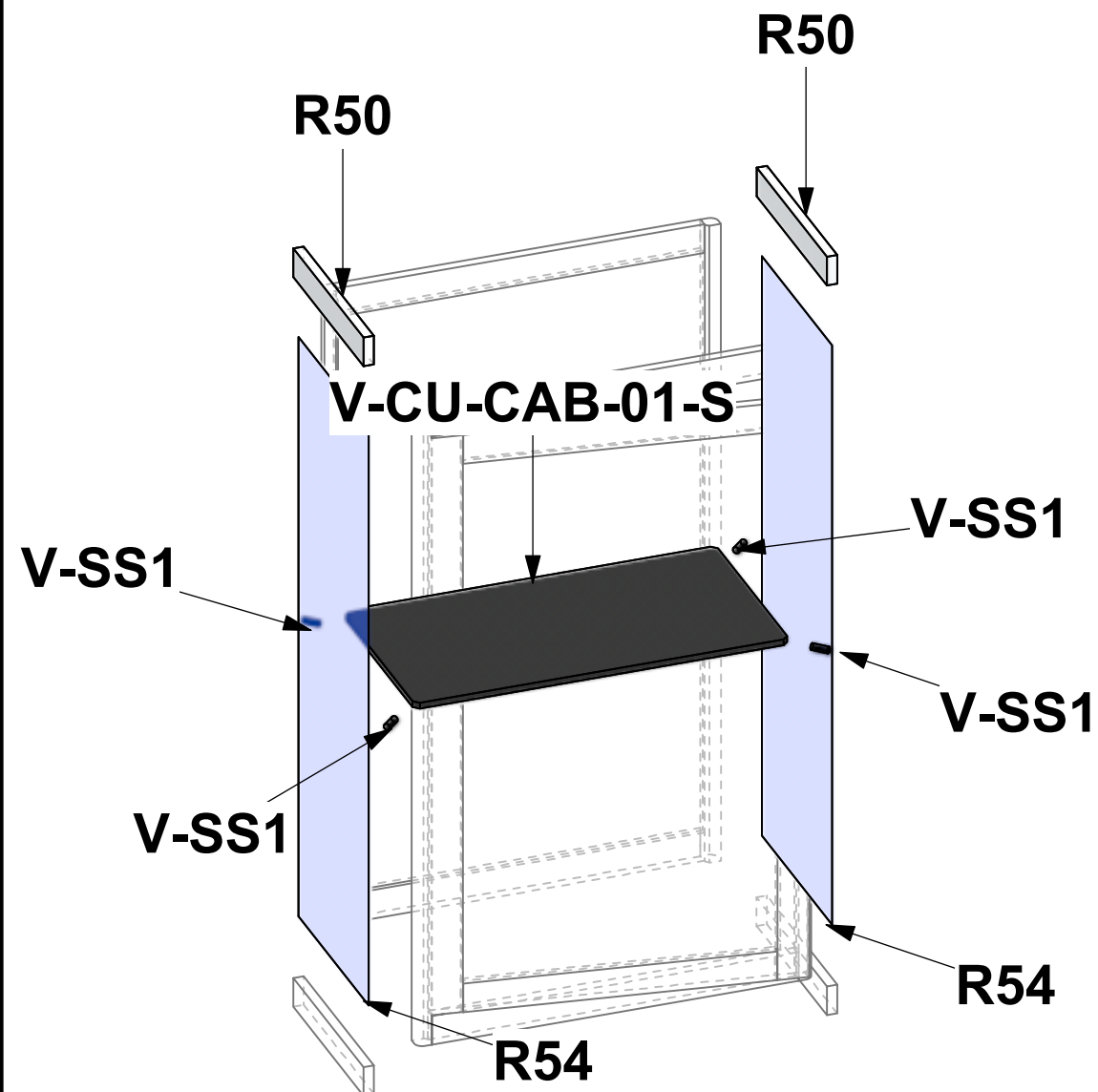

1. Redesign of this exhibit without approval by manufacturer may result in dangerous and unsafe structures. Manufacturer disclaims any responsibility for redesigned exhibits it does not approve in writing.

2. Parts and components such as panels and extrusions are manufactured to metric sizing. Where ever possible sizes have been noted in feet and inches as well as in metric. Below is the imperial to metric sizing table as reference. *Nominal" refers to approximate size.

2400mm = (94 1/2")	Phone Line / Fax
2100mm = (82 5/8")	Internet connection
1800mm = (70 7/8")	Outlet
1500mm = (59")	Main Drop (point of distrution)
1200mm = (47 1/4")	
900mm = (35 1/2")	
600mm = (23 5/8")	
300mm = (11 7/8")	

--- Wire running under carpet

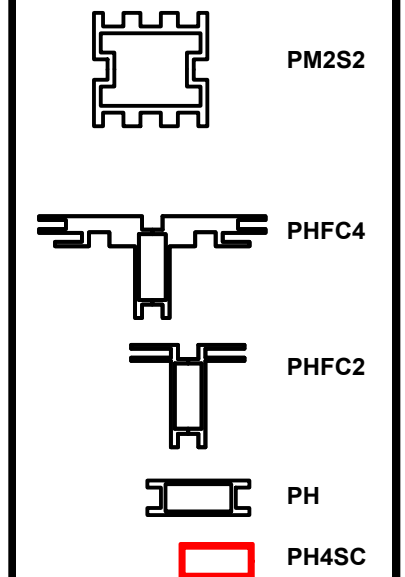

HYBRID PRO RENTAL KIT

Title: SET-UP INSTRUCTIONS

Code	#	Description
V-CW-CT-01	1	384MM X 646MM (15 1/8" X 25 7/16") HYBRID RECTANGLE TOP

1. Redesign of this exhibit without approval by manufacturer may result in dangerous and unsafe structures. Manufacturer disclaims any responsibility for redesigned exhibits it does not approve in writing.

2. Parts and components such as panels and extrusions are manufactured to metric sizing. Where ever possible sizes have been noted in feet and inches as well as in metric. Below is the imperial to metric sizing table as reference. "Nominal" refers to approximate size.

- 2400mm = (94 1/2") Phone Line / Fax
- 2100mm = (82 5/8") Internet connection
- 1800mm = (70 7/8")
- 1500mm = (59") Outlet
- 1200mm = (47 1/4")
- 900mm = (35 1/2") Main Drop (point of distrution)
- 600mm = (23 5/8")
- 300mm = (11 7/8")

--- Wire running under carpet

V-CW-CT-01

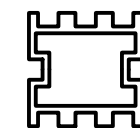
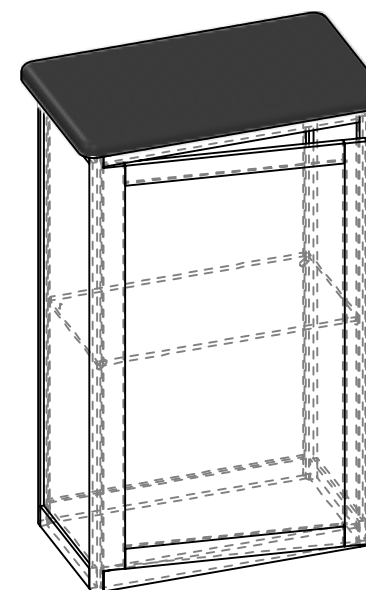
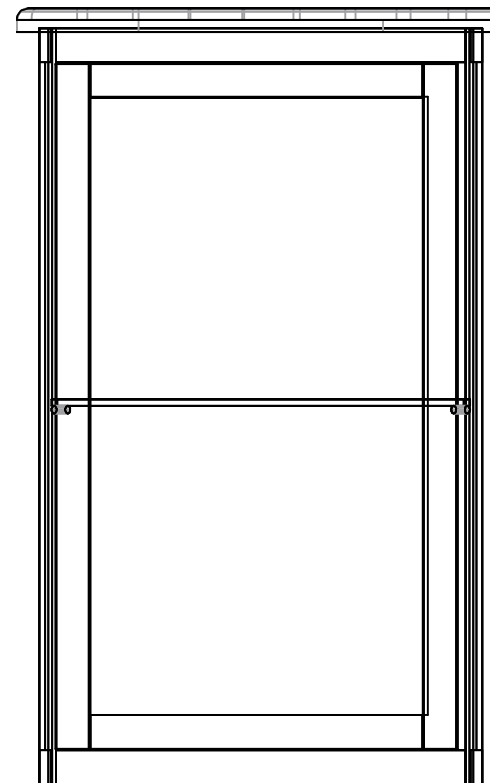
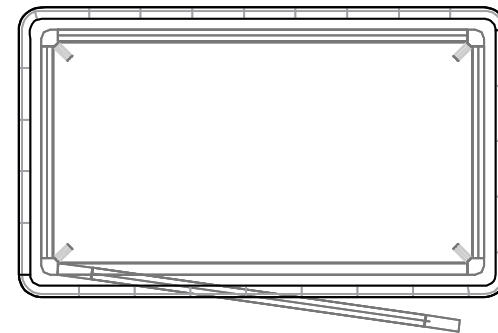
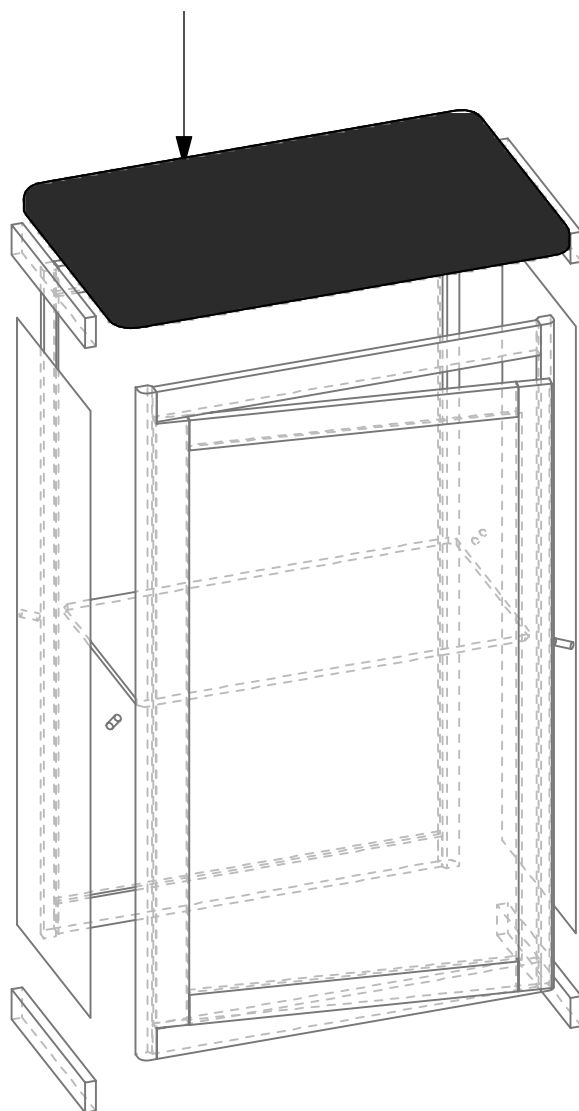

PM2S2

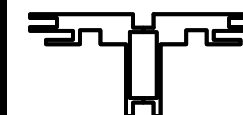

PHFC4



PHFC2



PH



PH4SC

HYBRID PRO RENTAL KIT

Title: SET-UP INSTRUCTIONS

PACKING INSTRUCTIONS

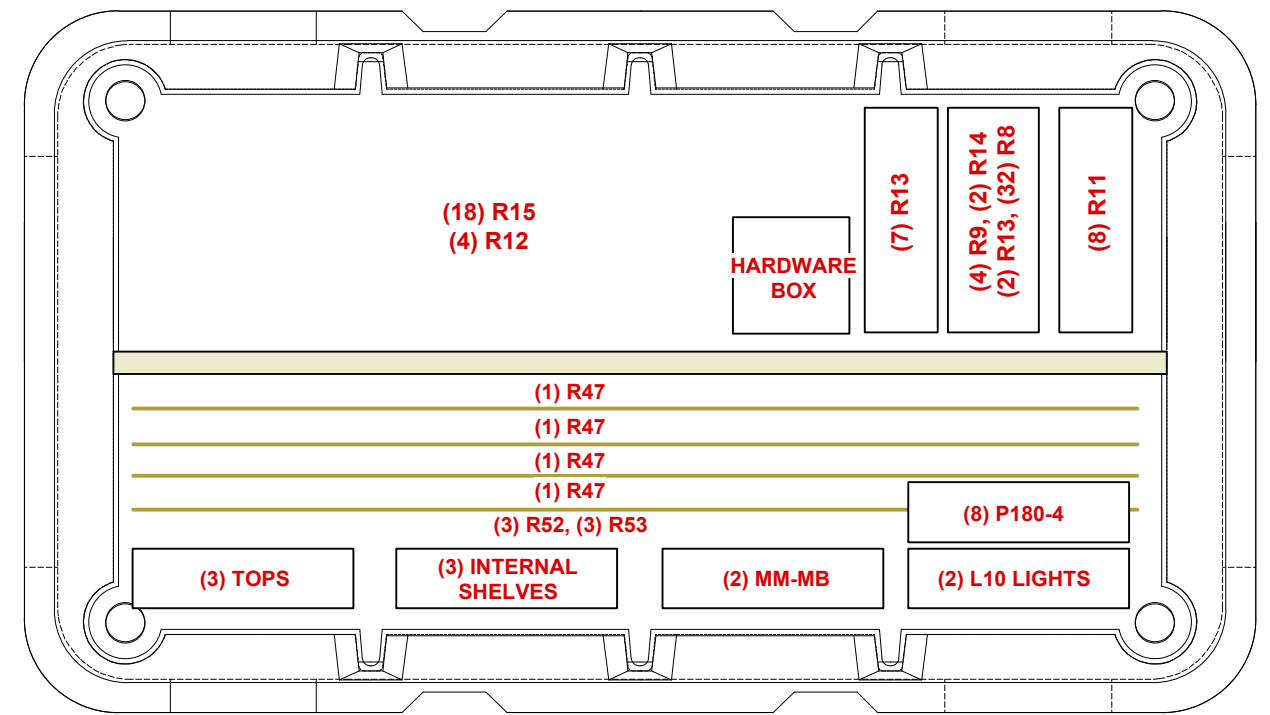

CASE # 1

LEGEND		GREY FOAM FOLDED TO FILL EMPTY SPACES OR USED AS PROTECTION
		1/8" CARDBOARD SPACER (PUT IN BETWEEN EVERY PANEL)
		DIVIDER
		1/4" WHITE FOAM (USED AS PROTECTION DOOR PANELS W/ LOCKS)



Monitor Bracket Instructions

Extrusion Channel Applications



EXT-SM-MB

Vesa Pattern: 75 x 75
up to 200 x 200mm

Max weight varies per application

Assembled unit:

10" w x 8.86" h x 2" d
255mm (w) x 225mm (h) x 50mm (d)

Shipping dimensions:

14" l x 6" h x 4" d
356mm (l) x 152mm (h) x 102mm (d)

Approximate total shipping weight:

6 lbs / 3 kg

Recommended monitor sizes:

23" - 42"

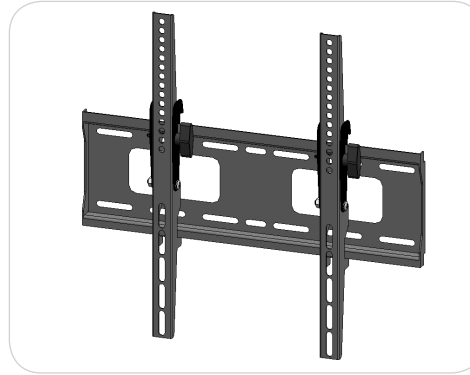

EXT-M-MB

Vesa Pattern: 200 x 200
up to 400 x 400mm

Max weight varies per application

Assembled unit:

17.6" w x 16.7" h x 1.6" d
448mm (w) x 425mm (h) x 40mm (d)

Shipping dimensions:

24" l x 4" h x 4" d
610mm (l) x 102mm (h) x 102mm (d)

Approximate total shipping weight:

8 lbs / 4 kg

Recommended monitor sizes:

32" - 55"

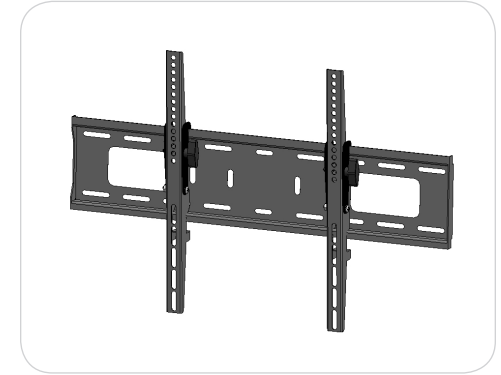

EXT-LG-MB

Vesa Pattern: 200 x 200
up to 600 x 400mm

Max weight varies per application

Assembled unit:

25.9" w x 16.7" h x 1.6" d
658mm (w) x 425mm (h) x 40mm (d)

Shipping dimensions:

28" l x 6" h x 6" d
711mm (l) x 152mm (h) x 152mm (d)

Approximate total shipping weight:

9 lbs / 5 kg

Recommended monitor sizes:

37" - 70"

Included hardware:

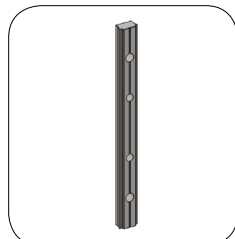

LN-100

x2



M5 x 10

LN-LCD-SCW

x2

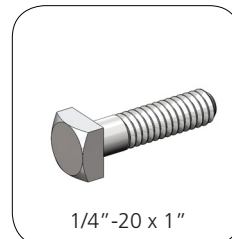

1/4"-20 x 1"

BOLT-1

x2

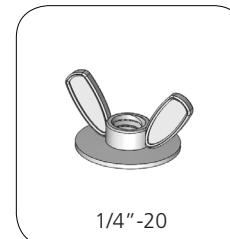

1/4"-20

Flange Wing nut

x2

Extrusion Connection

Channel Connection A

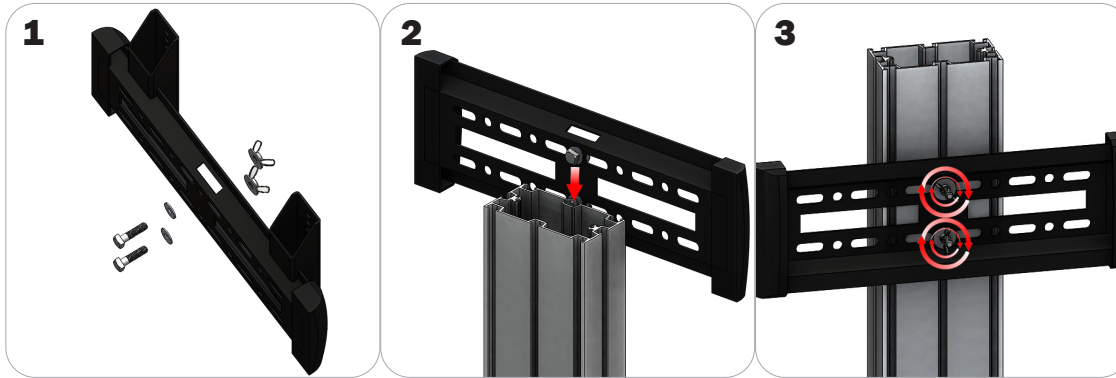

Locate all components needed to assemble the monitor mount with the channel connection A method. You will need (1) monitor bracket, (2) square head bolts, (2) washers, and (2) wing nuts.

Step 1: Insert the provided bolts through the washers and center top and bottom holes of the monitor mount. Loosely thread your wing nuts onto the end of the bolts.

Step 2: Slide the bolt heads down the extrusion channel.

Step 3: Tighten your wing nuts to lock the monitor bracket in place.

Step 4: Reference the included manufacturer monitor mount instructions for fastening your monitor to the bracket.

Channel Connection B

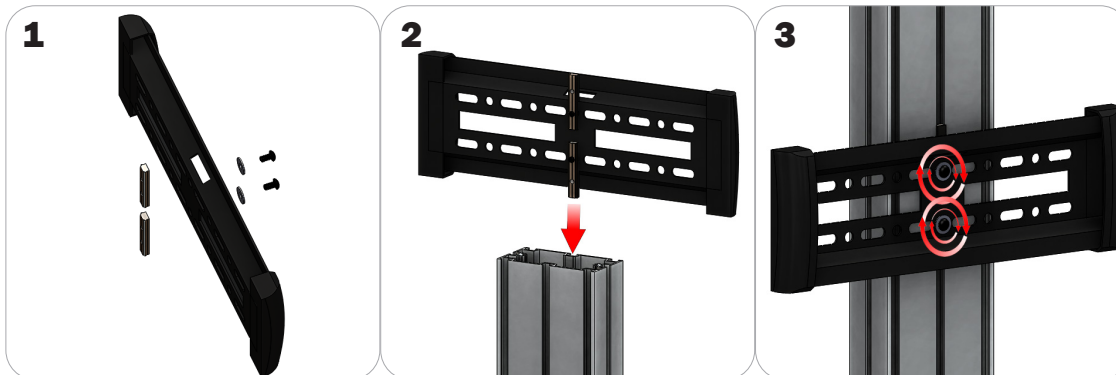

Locate all components needed to assemble the monitor mount with the channel connection B method. You will need (1) monitor bracket, (2) LN-LCD-SCW, (2) LN-100, and (2) washers.

Step 1: Loosely thread the LN-LCD-SCW screws through the washers, the center top and bottom holes of the monitor bracket, and through the LN-50 holes.

Step 2: Slide the LN-100s down the extrusion channel.

Step 3: Tighten your LN-LCD-SCW to lock the monitor bracket in place.

Step 4: Reference the included manufacturer monitor mount instructions for fastening your monitor to the bracket.

Extrusion Connection

TRI-30MM Channel Tube Connection

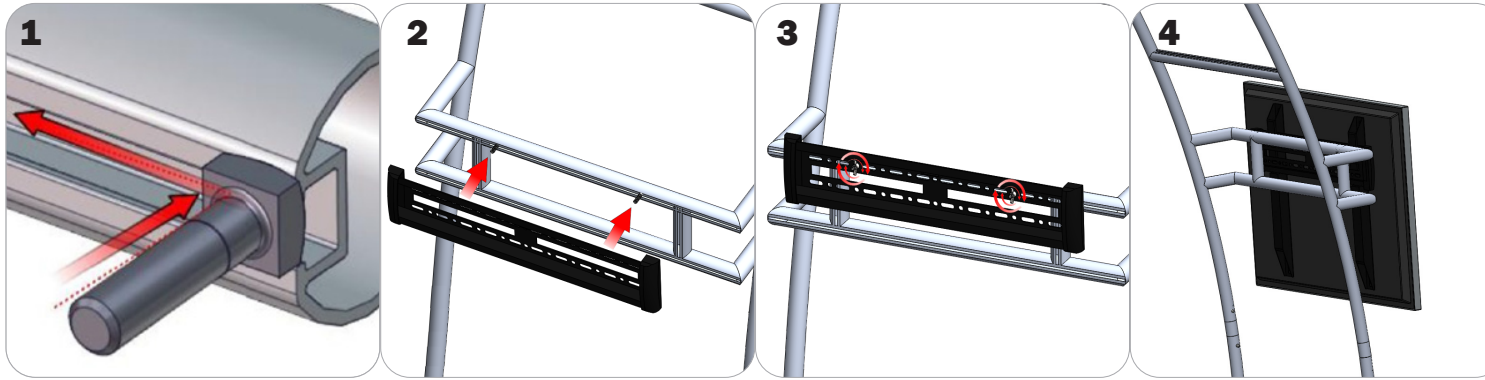

Locate all components needed to assemble the monitor mount with the TRI-30MM Channel Tube Connection method. You will need (1) monitor bracket, (2) Square Bolts, and (2) Wingnuts.

Step 1: Slip the head of the square bolts into the extrusion channel of the tube.

Step 2: Apply your monitor bracket to the protruding square bolts.

Step 3: Lock your monitor bracket to the square bolts using the provided wingnuts.

Step 4: Reference the included manufacturer monitor mount instructions for fastening your monitor to the bracket.